

Umformtechnik Stanzanwendungen

*Forming Technology
Piercing Applications*

Das Einbringen von zusätzlichen Löchern, Aussparungen oder Beschneidungen ist eines unserer Spezialgebiete in der Umformtechnik.

Als Stanzeinheiten setzen wir sowohl C-Bügel-Systeme als auch Kniehebelzangen ein (siehe nächste Seite).

Das vorliegende „Bilderbuch“ gibt Ihnen einen Überblick über typische Anwendungen, die wir in den letzten Jahren realisiert haben. Vielleicht finden sich hier auch Anregungen für Ihren aktuellen Anwendungsfall.

The insertion of additional holes, recesses or trimming is one of our specialties in forming technology.

As punching units we use both C-frame systems and toggle-type tongs (see next page).

This "picture book" gives you an overview of typical applications that we have realized in recent years. You may also find suggestions for your current application here.

Beispiel Kniehebelzange PFS

Example toggle unit PFS

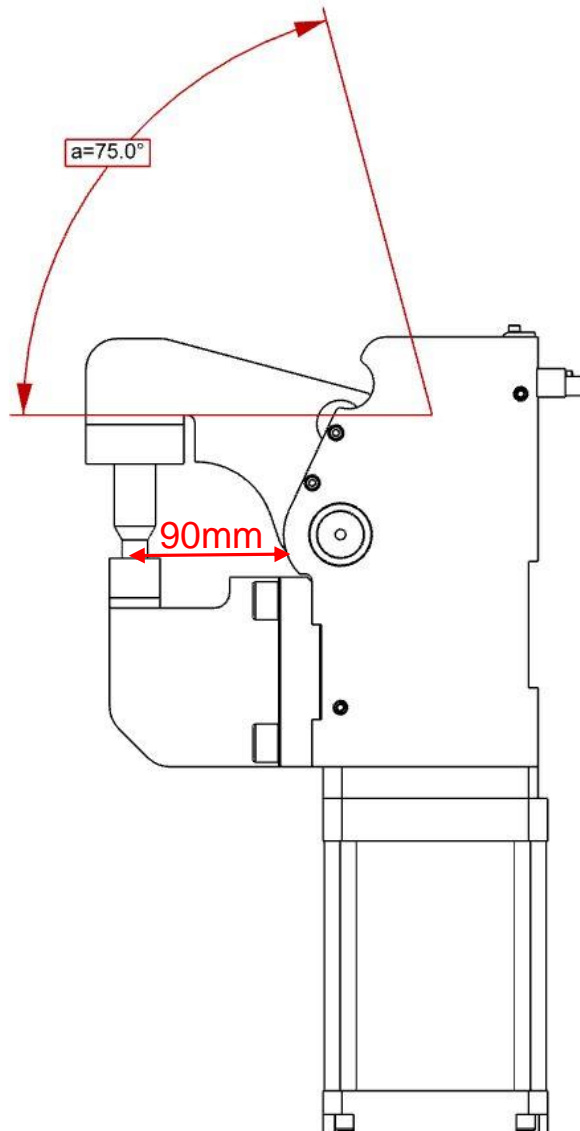

PFS 400-90 S T12/3 75° 125mm

PFS: pneumatische Kniehebelzange / *pneumatic toggle unit*

400: Baugröße / *Size*

90: Ausladung [in mm] / *Reach [in mm]*

S: Stanzen/Schneiden / *Piercing/Cutting*

T12/3: Abfragesystem / *Sensor*

75°: Öffnungswinkel / *opening angle*

125mm: Zylinder-Ø / *cylinder Ø*

Abfragesysteme / *Sensors*

T12: induktive Abfrage 24V, 1 Abgang mit 3 integrierten LEDs
inductive Sensor 24 V, 1 outlet with 3 integrated LEDs

T08: pneumatische Abfrage / *pneumatic sensor*

Öffnungswinkel max. 75° / *Opening angle max. 75°*

Medium

Luft, max. 6 bar, Betrieb mit ölfreier Luft zulässig

Air, max. 6 bar, operation permitted with oil-free air

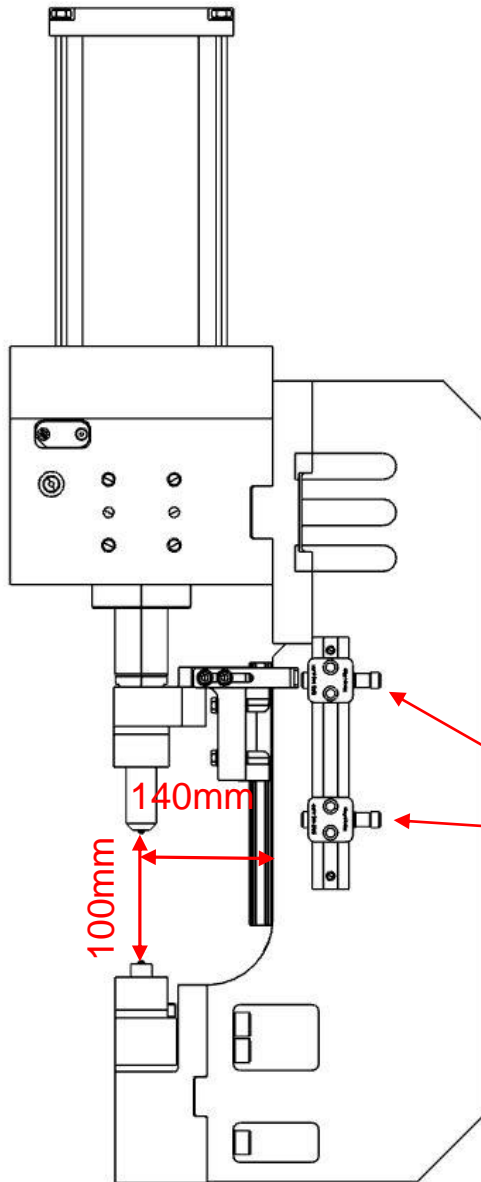

CBMZ 10-140 100 S T02

CB: C-Bügeleinheit / *C-frame unit*

MZ: Antrieb / *Drive*

MZ: Multikraftzylinder / *Multi-power cylinder*

HZ: Hydraulikzylinder / *hydraulic cylinder*

HA: HydroAir Zylinder / *HydroAir cylinder*

10: Stanzkraft [in kN] / *Piercing force [in kN]*

140: Ausladung [in mm] / *Reach [in mm]*

100: Zylinderhub [in mm] / *Cylinder stroke [in mm]*

S: Stanzen/Schneiden / *Piercing/Cutting*

T02: Abfragesystem / *Sensor*

Abfragesysteme / *Sensors*

T02: 2x externe induktive Abfrage M12

2x external inductive Sensor M12

T08: 2x externe pneumatische Abfrage / *2x external pneumatic sensor*

Ausladung / *Reach*

Standard: 140mm, 200mm, 300mm *

*weitere Maße auf Anfrage / *further measurements upon request*

Vollelektrische Federbeinlochanlage

Electric shock tower piercing unit

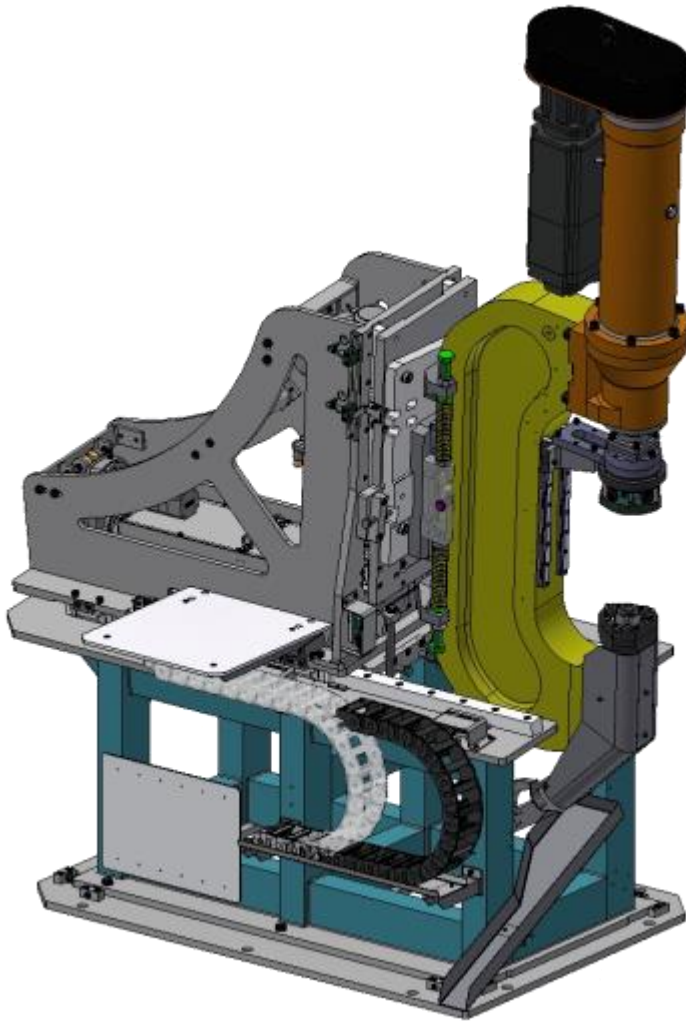

- E-Antrieb mit Planetengewindetrieb
- $F_{\max} = 250 \text{ kN}$, Ausladung 235 mm, Hub 360 mm
- Taktzeit < 28 sec
- *Performance data*
- *E-Drive with planetary screw assemblies*
- $F_{\max} = 250 \text{ kN}$, reach 235 mm, stroke 360 mm
- *Cycle Time < 28 sec*

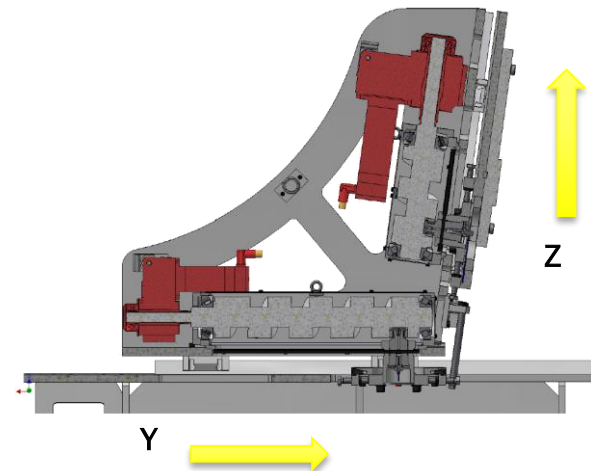

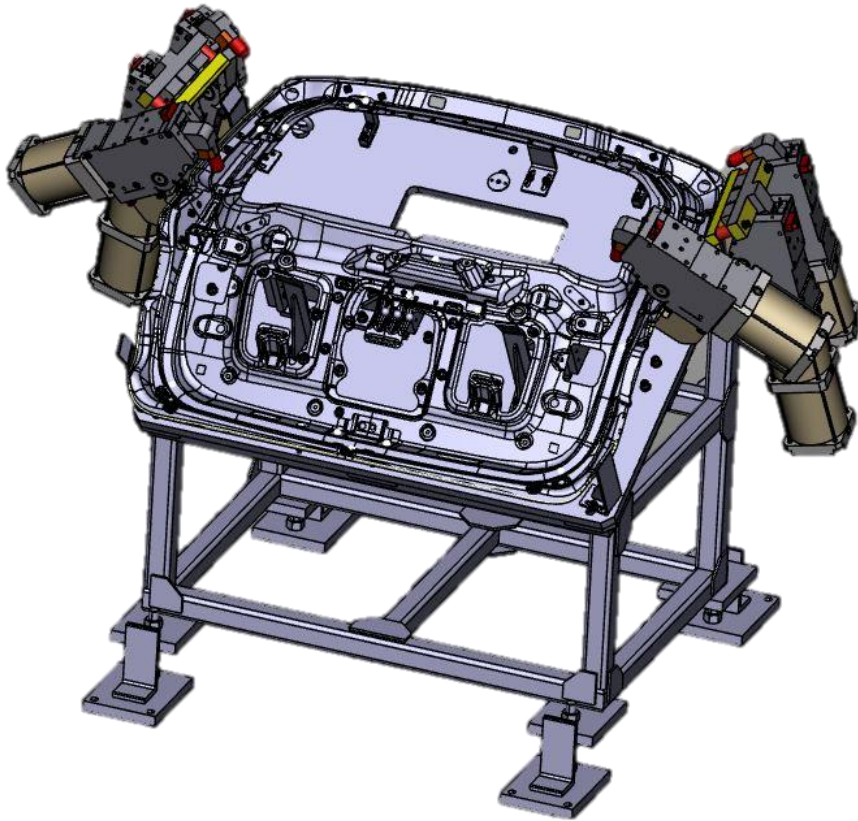

Kunde / Customer: SAIC (China)

- PFS 400-90 S 70° für 1x Ø 8,5mm
 - PFS 900-90 S 70° für 2x Ø 8,5mm und 1x Ø14mm
 - Konturmatrizen angepasst an Bauteiloberfläche
 - Stahlblech 0,65mm dick
-
- *PFS 400-90 S 70° for 1x Ø 8,5mm*
 - *PFS 900-90 S 70° for 2x Ø 8,5mm and 1x Ø14mm*
 - *Dies with 3D surface according to part contour*
 - *Steel sheet 0,65mm thick*

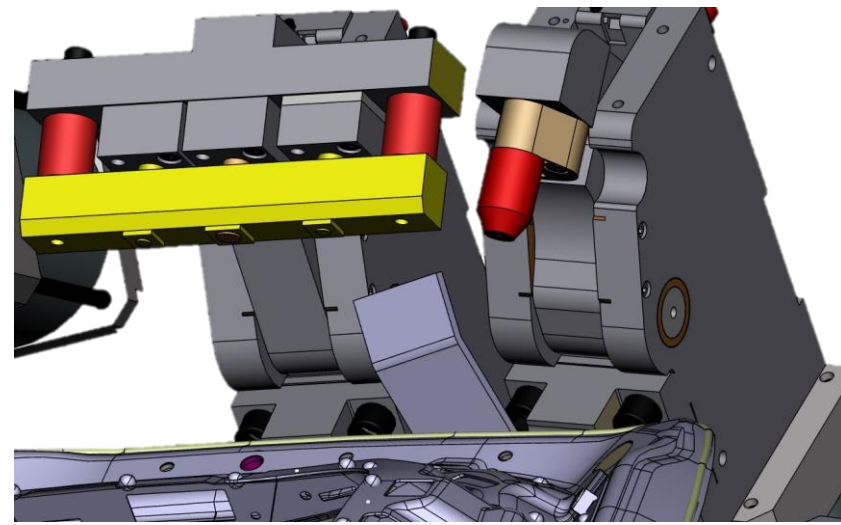

Stanzan mit CBPZ – A-Säule

Piercing with CBPZ – A-pillar



Kunde / Customer: AUDI (Bratislava)

- CBPZ 4-50 40 S für Ø 3,3mm
 - Pneumatikzylinder mit 40mm Hub
 - 50mm Ausladung
 - Butzenabfuhr per Vakuumabsaugung
 - Aluminiumblech 1,15mm dick
-
- *CBPZ 4-50 40 S for Ø 3,3mm*
 - *Pneumatic cylinder with 40mm stroke*
 - *50mm reach*
 - *vacuum unit for slug disposal*
 - *Aluminium sheet 1,15mm thick*

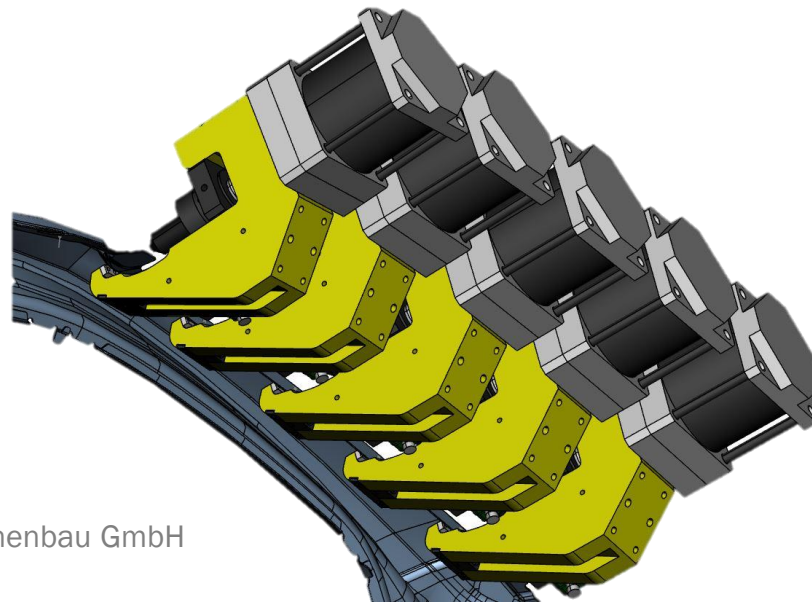

Stanzan mit CBMZ – Türrahmen hinten

Piercing with CBMZ – Door frame rear door

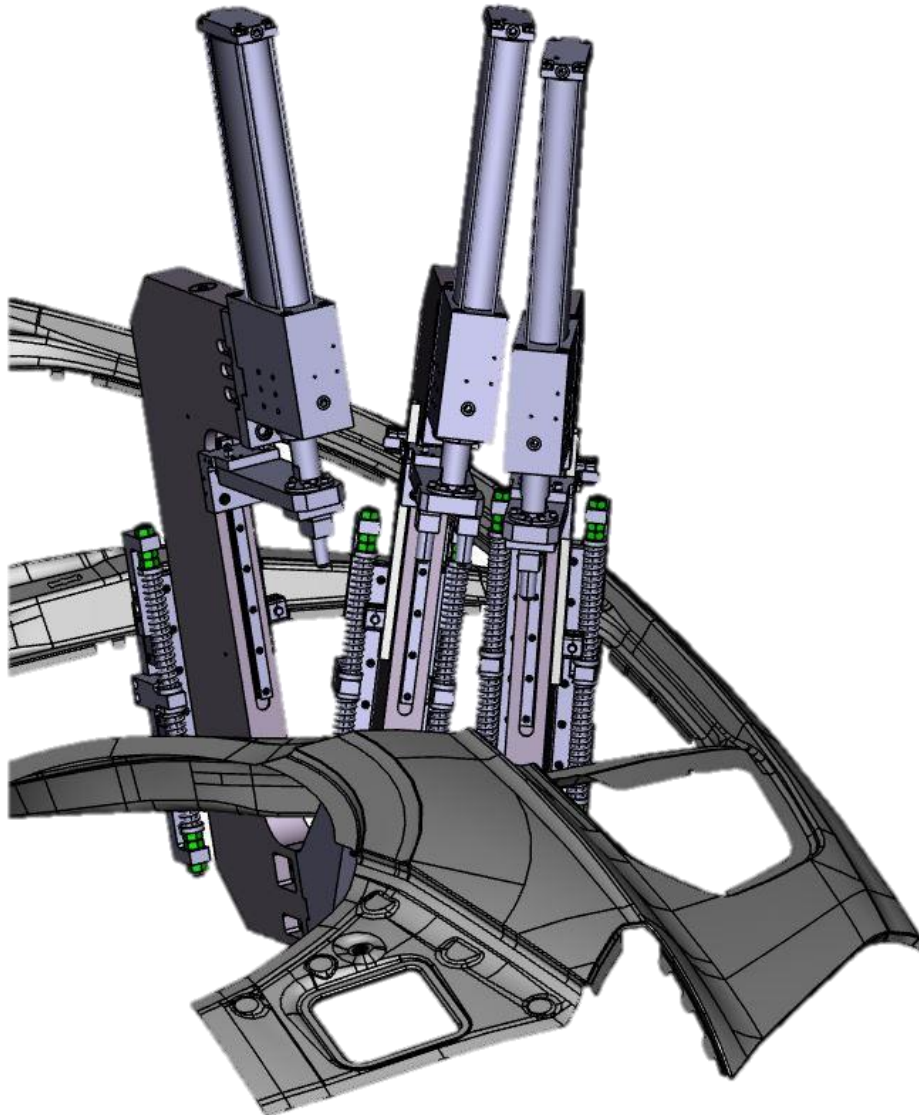

Kunde / *Customer:* AUDI (Bratislava)

- CBMZ 25-300 250 S für Ø 5,5mm Löcher
 - MZ 80 (25kN) mit 250mm Hub
 - 300mm Ausladung
 - Aluminiumblech 1,15mm dick
-
- *CBMZ 25-300 250 S for Ø 5,5mm holes*
 - *MZ 80 (25kN) with 250mm stroke*
 - *300mm reach*
 - *Aluminium sheet 1,15mm thick*

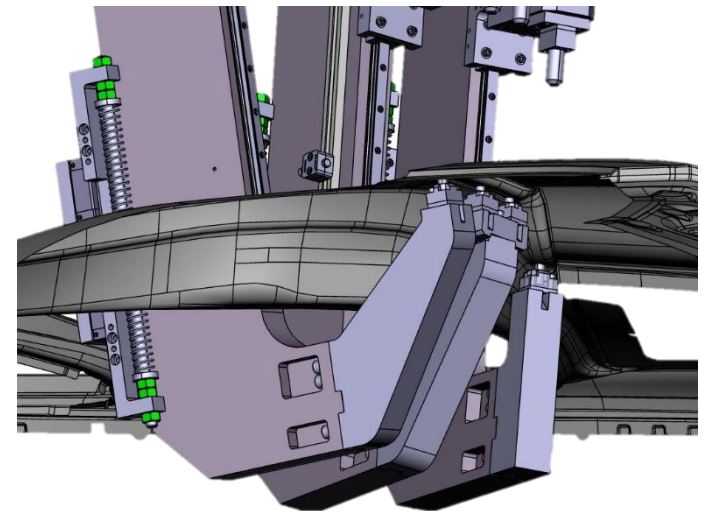

Stanzan mit CBMZ – Heckleuchte

Piercing with CBMZ – tail light

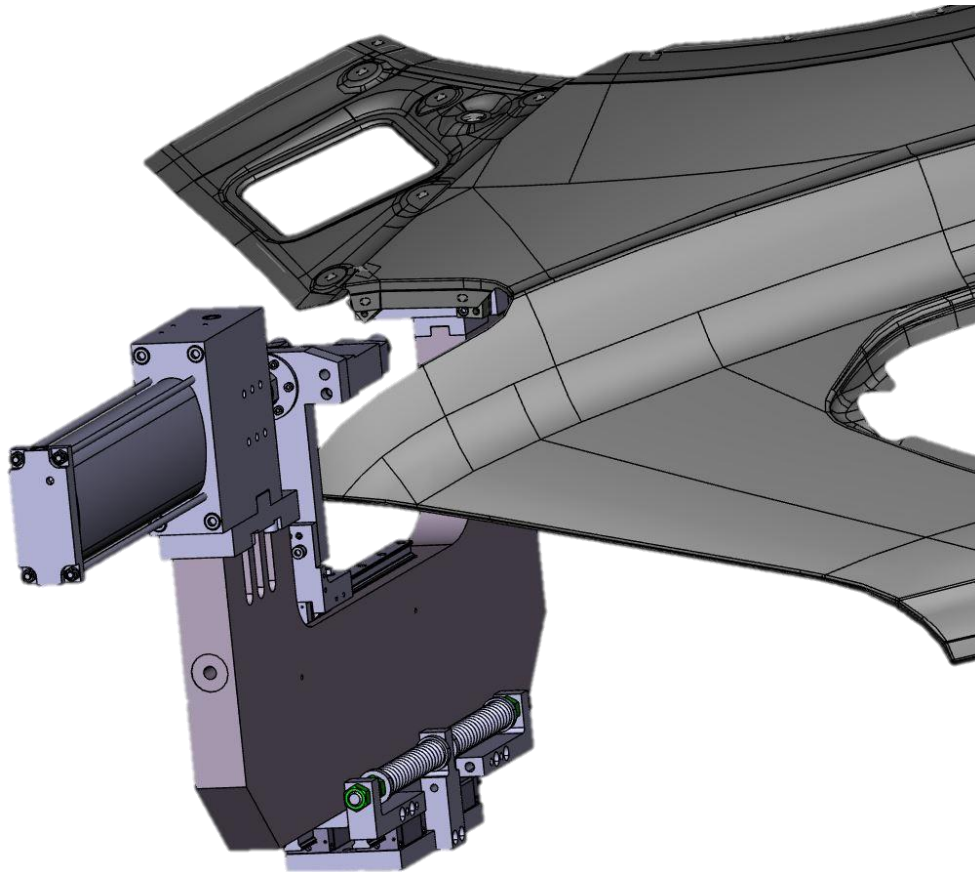

Kunde / Customer: AUDI (Bratislava)

- CBMZ 25-250 250 S für 2x 11x7mm Langlöcher
- MZ 80 (25kN) mit 250mm Hub
- 250mm Ausladung
- Aluminiumblech 1,15mm dick
- *CBMZ 25-250 250 S for 2x 11x7mm oblong holes*
- *MZ 80 (25kN) with 250mm stroke*
- *250mm reach*
- *Aluminium sheet 1,15mm thick*

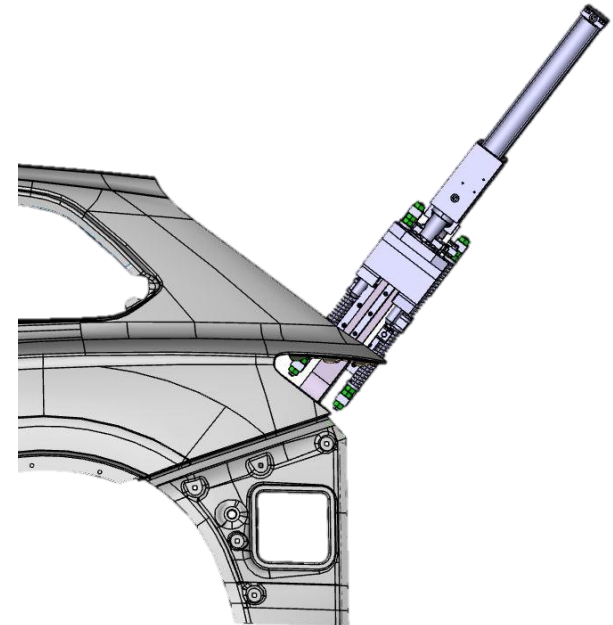

Stanzan mit CBMZ – Stirnwan Rechtslenker

Piercing with CBMZ – head wall RHD

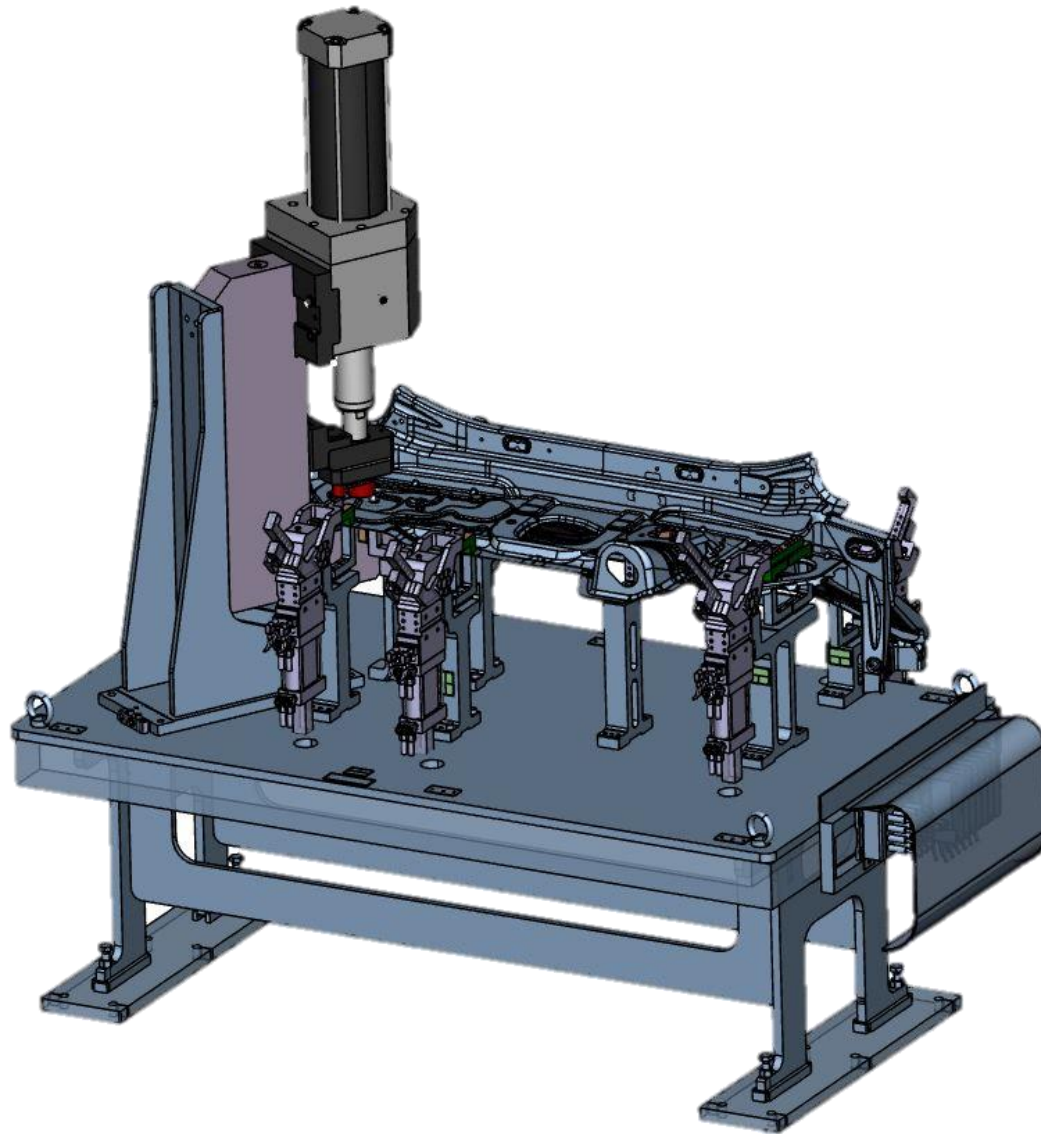

Kunde / Customer: AUDI

- CBMZ 60-140 100 S für 1x Ø 40,2mm + 1x Ø 6,7mm Löcher
- MZ 140 (60kN) mit 100mm Hub
- Aluminiumblech 1mm dick

- *CBMZ 60-140 100 S for 1x Ø 40,2mm + 1x Ø 6,7mm holes*
- *MZ 140 (60kN) with 100mm stroke*
- *Aluminium sheet 1mm thick*

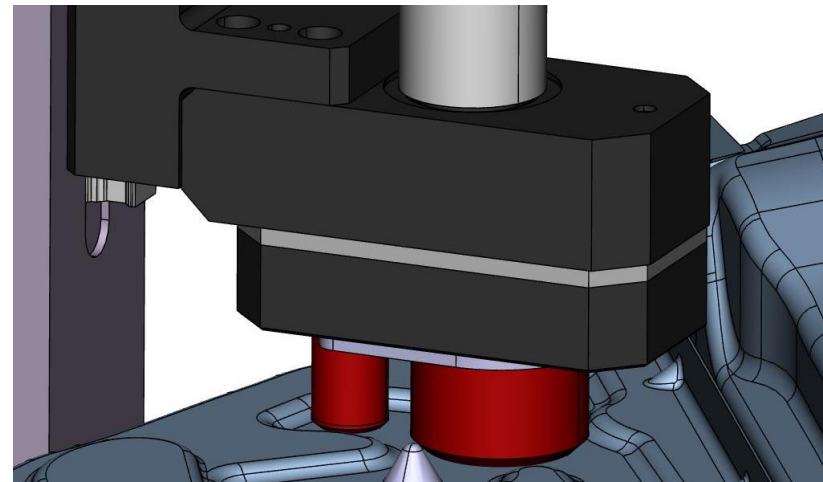

Kunde / *Customer: VW*

- CBMZ 60-400 100 S für Langloch 35x60mm
 - MZ 140 (60kN) mit 100mm Hub
 - 400mm Ausladung
 - Stahlblech 0,7mm dick
-
- *CBMZ 60-400 100 S for oblong hole 35x60mm*
 - *MZ 140 (60kN) with 100mm stroke*
 - *400mm reach*
 - *Steel sheet 0,7mm thick*

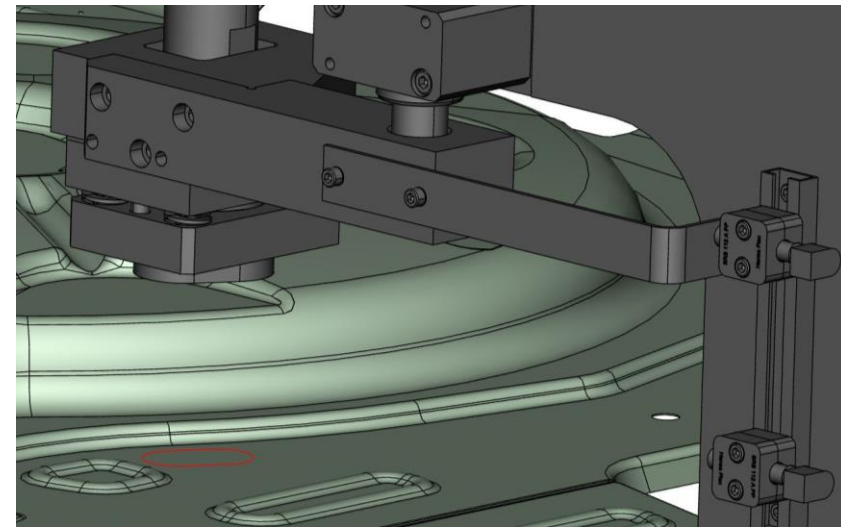
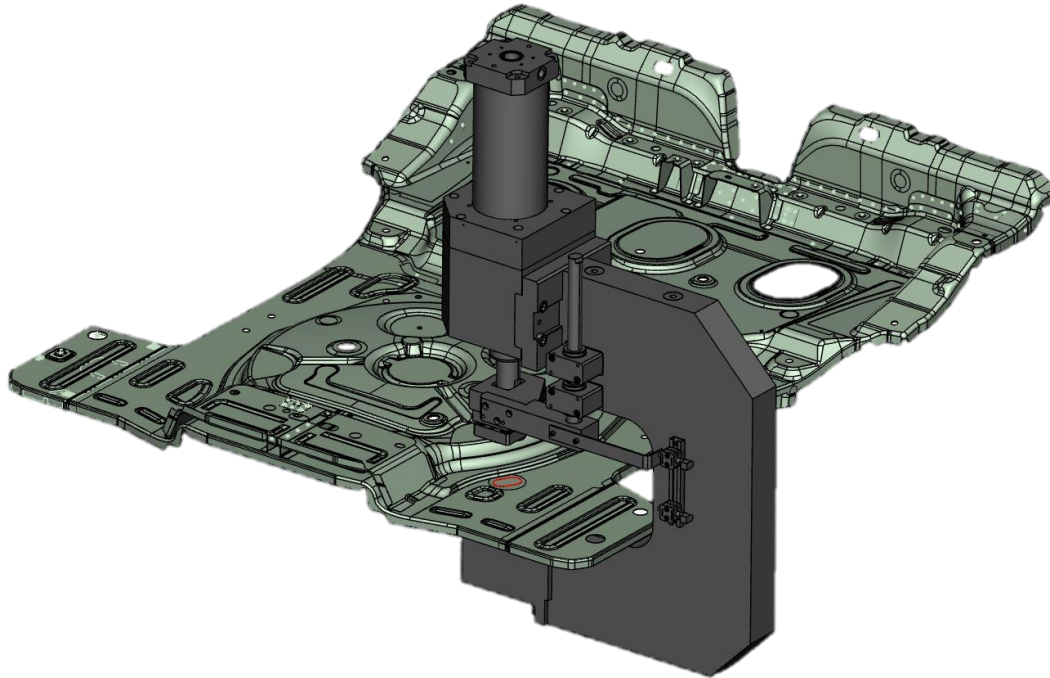

Stanzan mit CBMZ – Reserveradmule

Piercing with CBMZ – spare wheel well

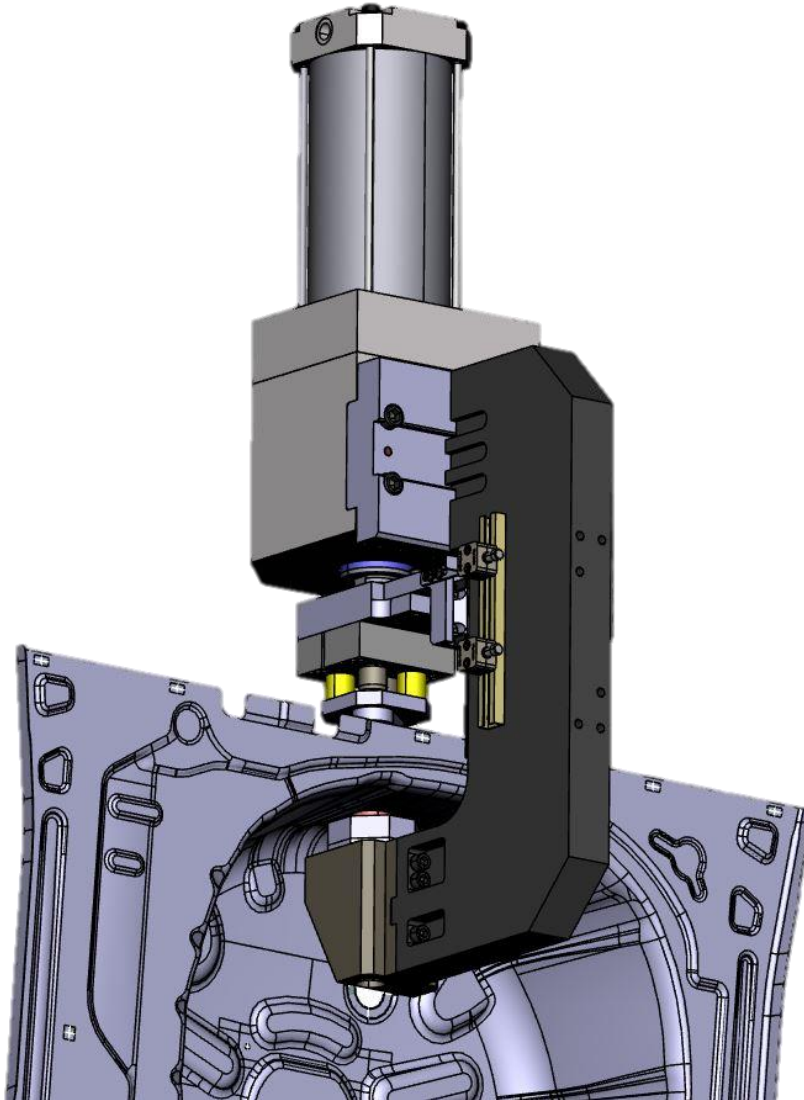

Kunde / Customer: Seat

- CBMZ 60-200 100 S für 1x Ø 40,2mm + 1x Ø 30,2mm Löcher
- MZ 140 (60kN) mit 100mm Hub
- 200mm Ausladung
- Stahlblech 0,7mm dick

- *CBMZ 60-200 100 S for 1x Ø 40,2mm + 1x Ø 30,2mm holes*
- *MZ 140 (60kN) with 100mm stroke*
- *200mm reach*
- *Steel sheet 0,7mm thick*

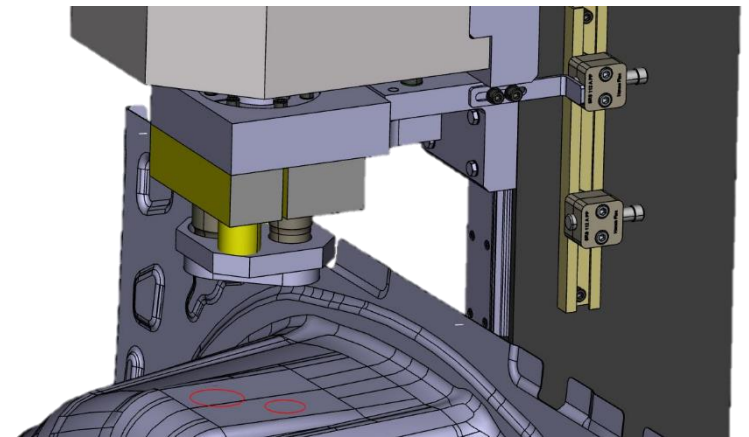

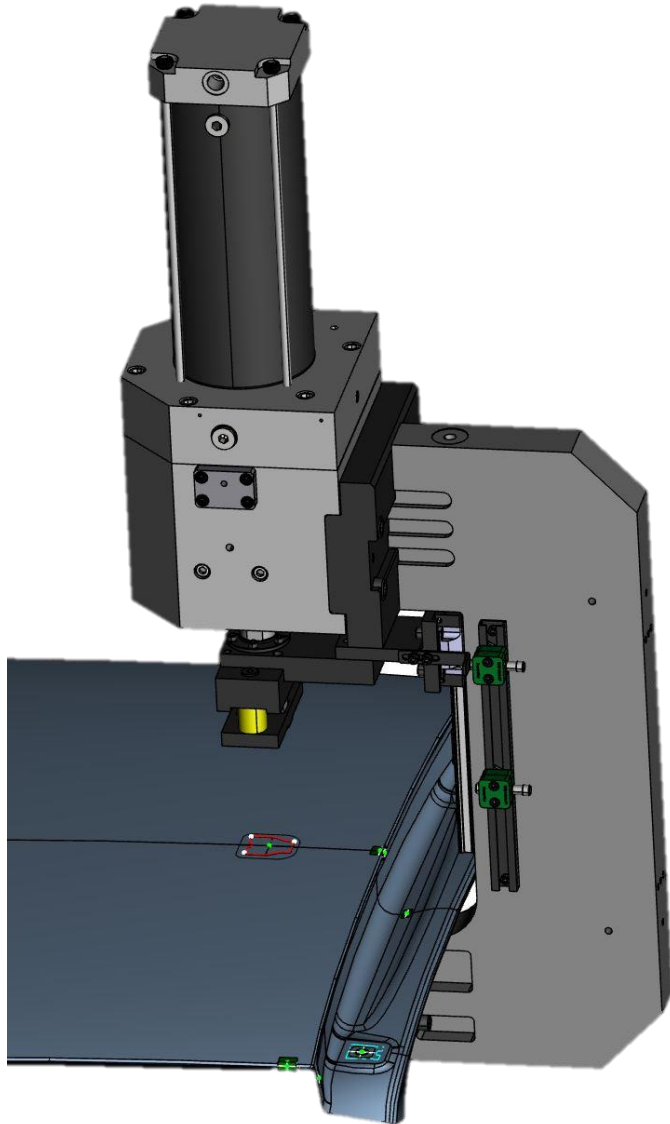

Kunde / *Customer: Seat*

- CBMZ 60-235 150 S
 - MZ 140 (60kN) mit 150mm Hub
 - 235mm Ausladung
 - Stahlblech 0,7mm dick
-
- *CBMZ 60-235 150 S*
 - *MZ 140 (60kN) with 150mm stroke*
 - *235mm reach*
 - *Steel sheet 0,7mm thick*

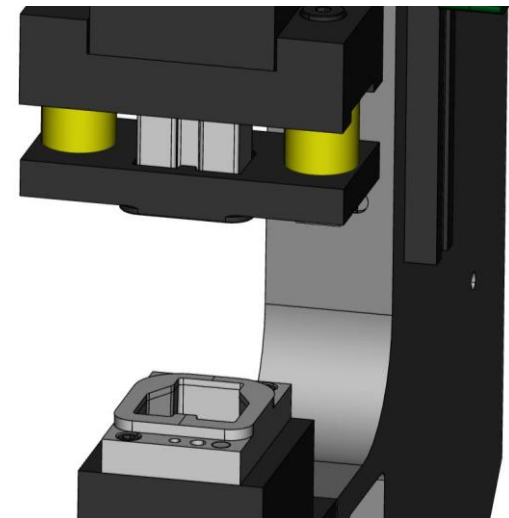

Stanzen mit CBHA – Heckklappe

Piercing with CBHA – rear door

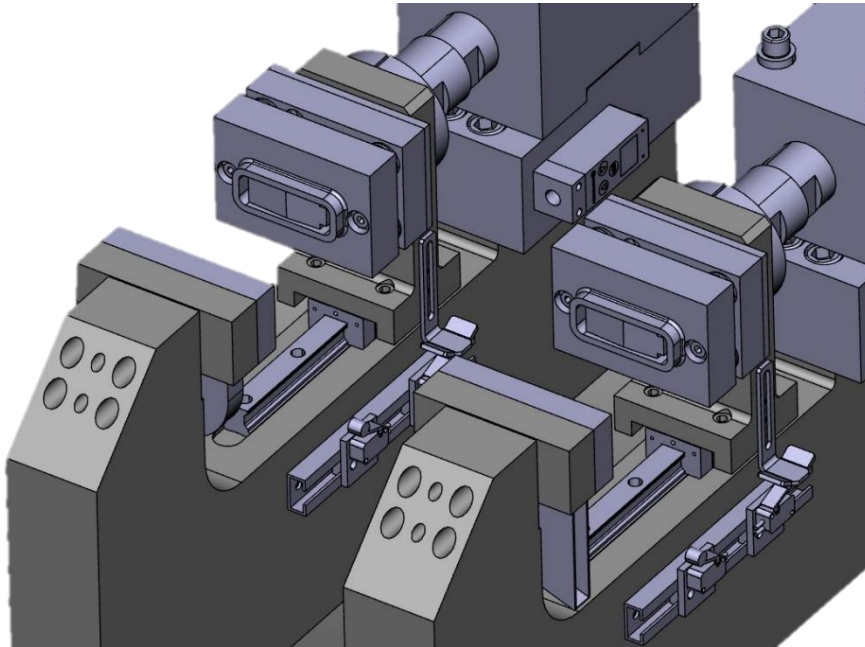

Kunde / Customer: DPCA (China)

- CBHA 60-140-100 S
- Kraftpaket U80 (60kN bei 5 bar) mit 100mm Hub
- 140mm Ausladung
- Stahlblech 0,65mm dick

- *CBHA 60-140-100 S*
- *Powerpackage U80 (60kN) with 100mm stroke*
- *140mm reach*
- *Steel sheet 0,65mm thick*

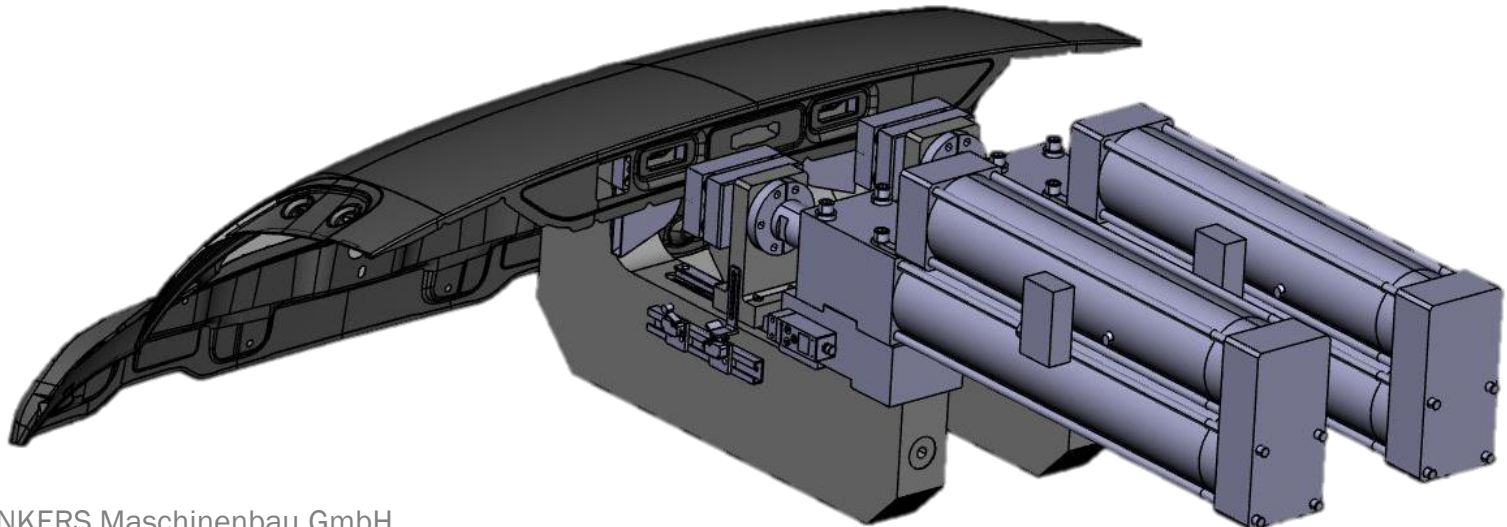

Stanzen mit CBMZ – Türrahmen

Piercing with CBMZ – door frame

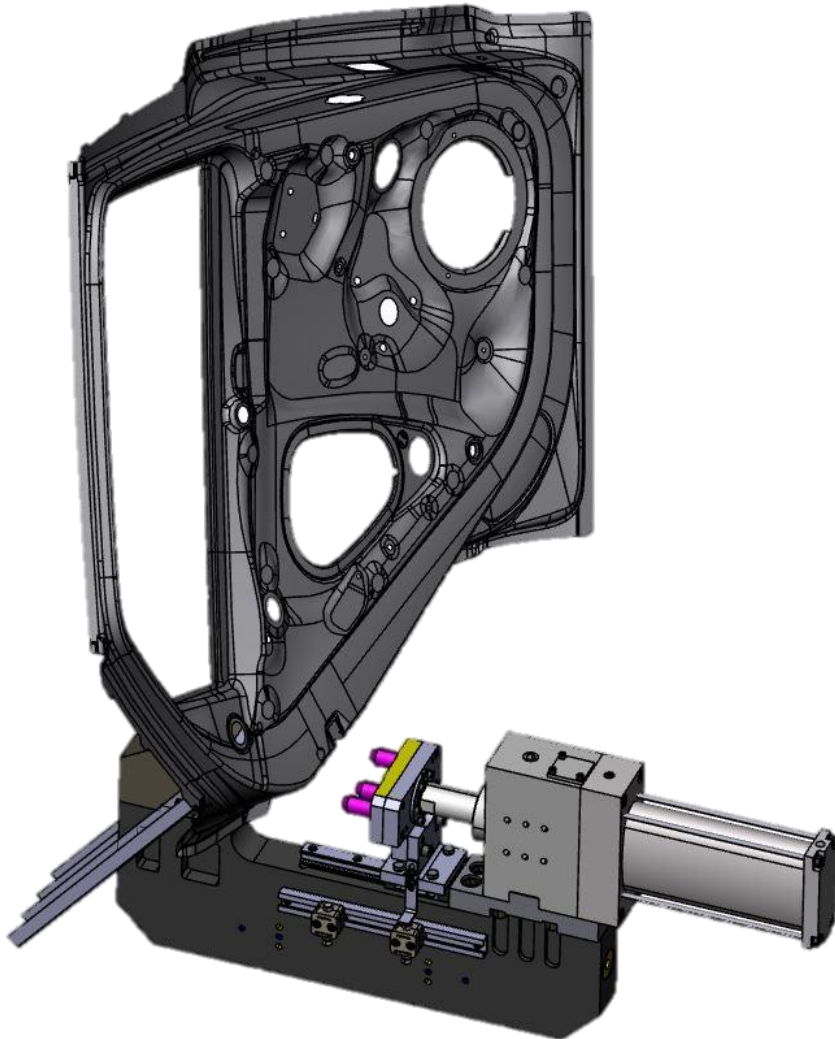

Kunde / Customer: AUDI

- CBMZ 25-140 100 S für 3x Ø 9mm Löcher
 - MZ 80 (25kN) mit 100mm Hub
 - C-Bügel mit 140mm Ausladung
 - Stahlblech 0,7mm dick
-
- *CBMZ 25-140 100 S for 3x Ø 9mm holes*
 - *MZ 80 (25kN) with 100mm stroke*
 - *C-Frame with 140mm reach*
 - *Steel sheet 0,7mm thick*

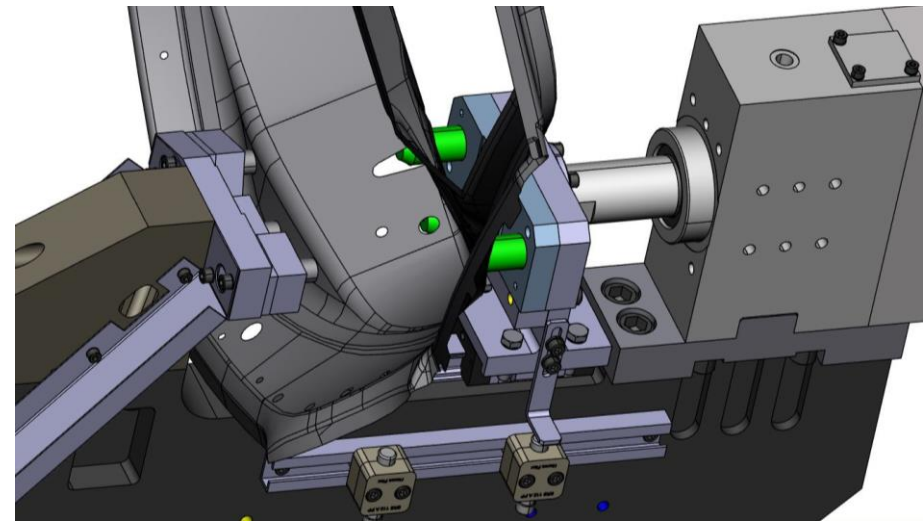

Abschneiden mit PFS – Türrahmen innen

Cutting with PFS – Door frame

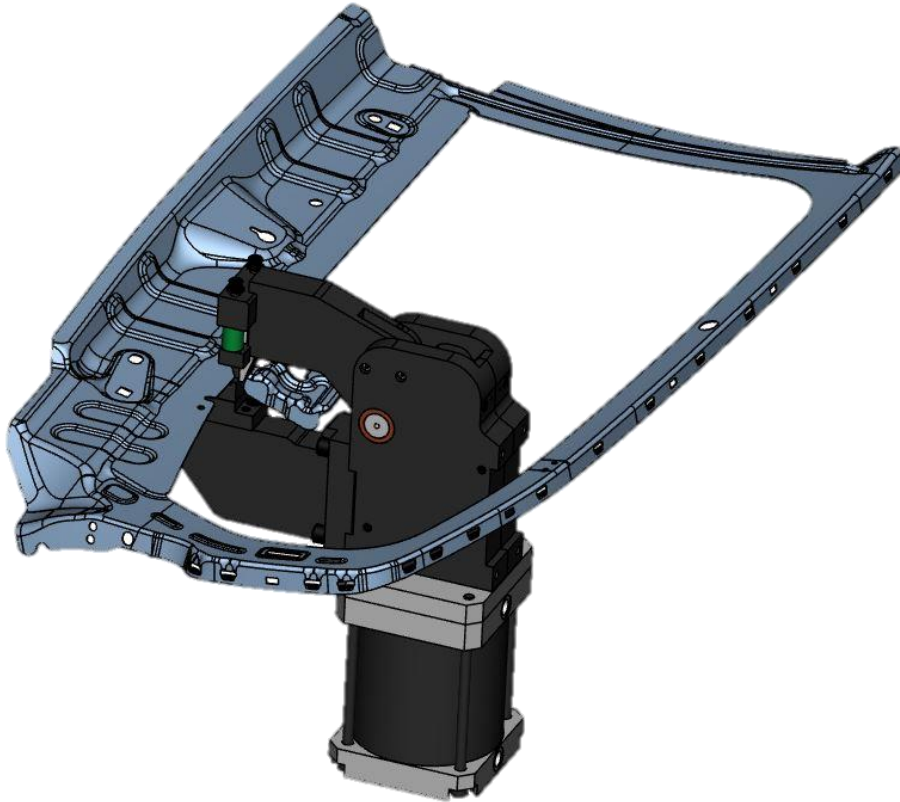

Kunde / Customer: PSA

- PFS 200-120 S T12/2 70°
 - Ausladung 120mm; Öffnungswinkel 70°
 - Schnittlänge 10mm
 - Stahlblech 0,95mm dick
-
- *PFS 200-120 S T12/2 70°*
 - *Reach 120mm; Opening angle 70°*
 - *Cutting length 10mm*
 - *Steel sheet 0,95mm thick*

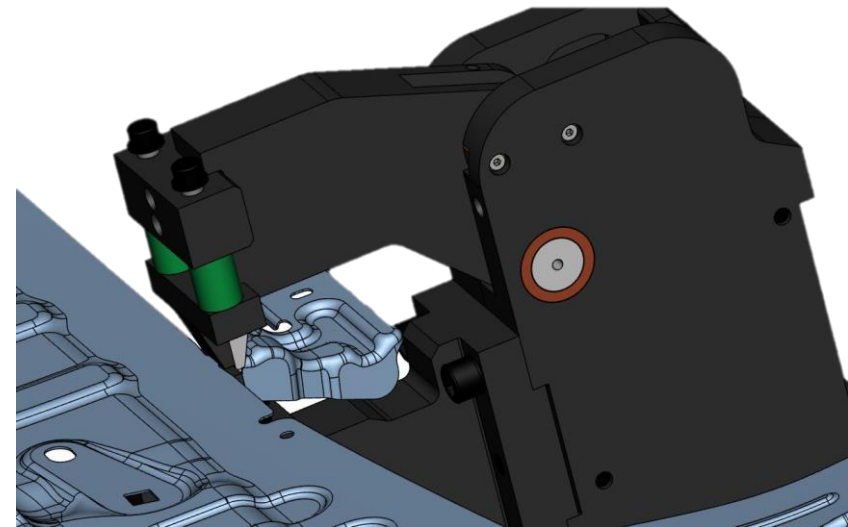

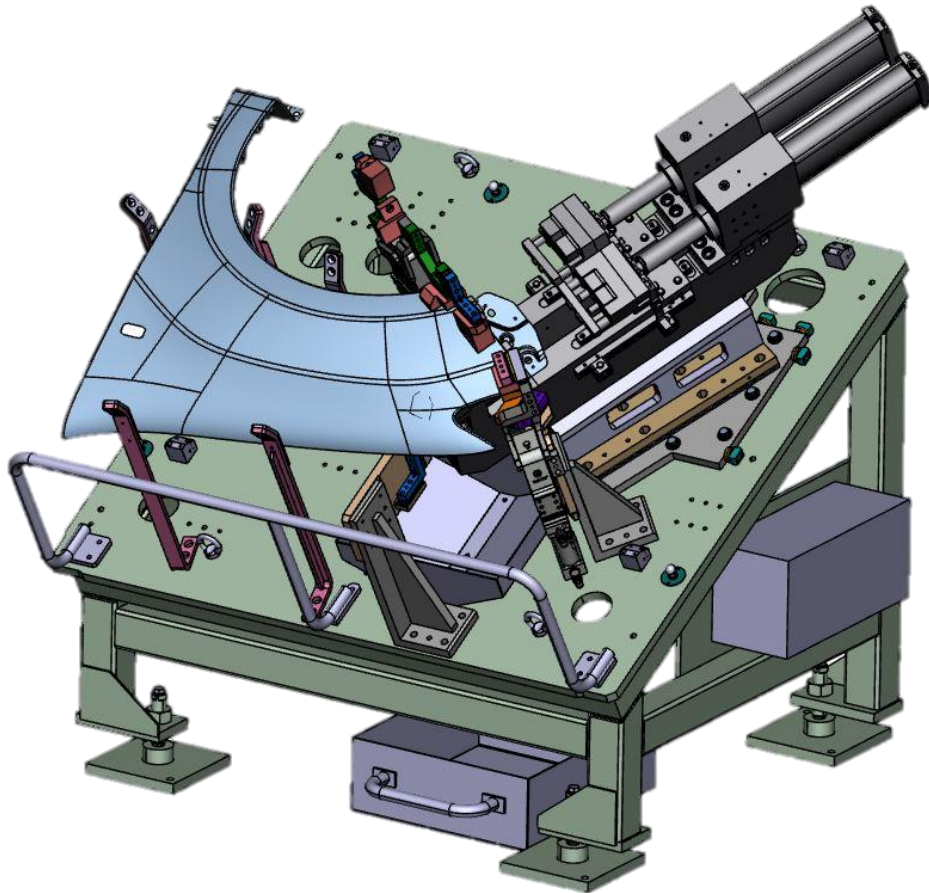

Kunde / Customer: Dacia

- CBMZ 25-140 150 S für Rechteck- und Sechskantlöcher
 - MZ 80 (25kN) mit 150mm Hub
 - C-Bügel mit 140mm Ausladung
 - Stahlblech 0,65mm dick
-
- *CBMZ 25-140 150 S for rectangular and hexagonal holes*
 - *MZ 80 (25kN) with 150mm stroke*
 - *C-Frame with 140mm reach*
 - *Steel sheet 0,65mm thick*

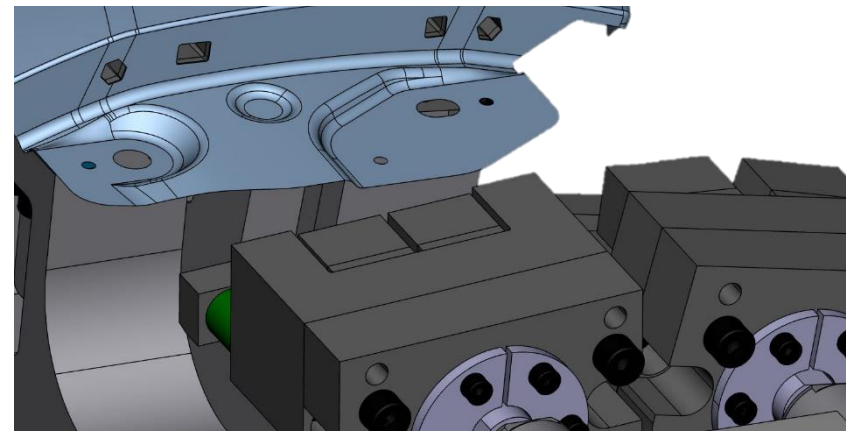

Stanzan mit PFS – Seitenteil

Piercing with PFS – Side panel

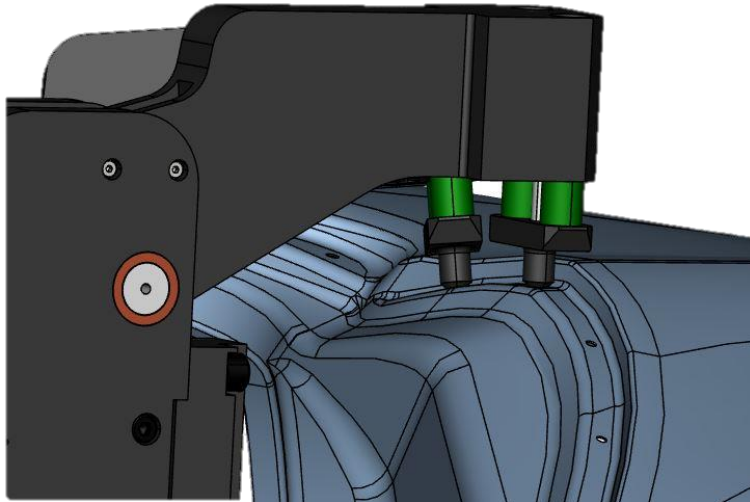

Kunde / Customer: Saab

- PFS 200-100 S 75° für Ø 6,4mm Loch
- Ausladung 100mm; Öffnungswinkel 75°
- Zylinder: Tandemausführung flachoval
- Stahlblech 0,8mm dick

- *PFS 200-100 S 75° for Ø 6,4mm hole*
- *Reach 100mm; Opening angle 75°*
- *Cylinder: Tandem version flat oval*
- *Steel sheet 0,8mm thick*

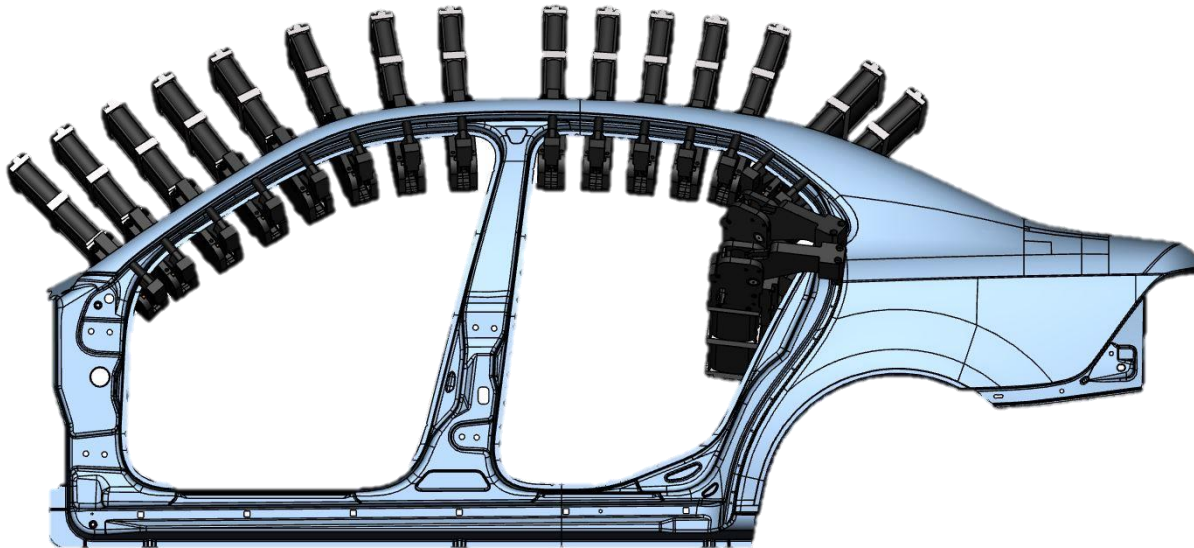

Abschneiden mit PFS – Türrahmen

Cutting with PFS – Door frame

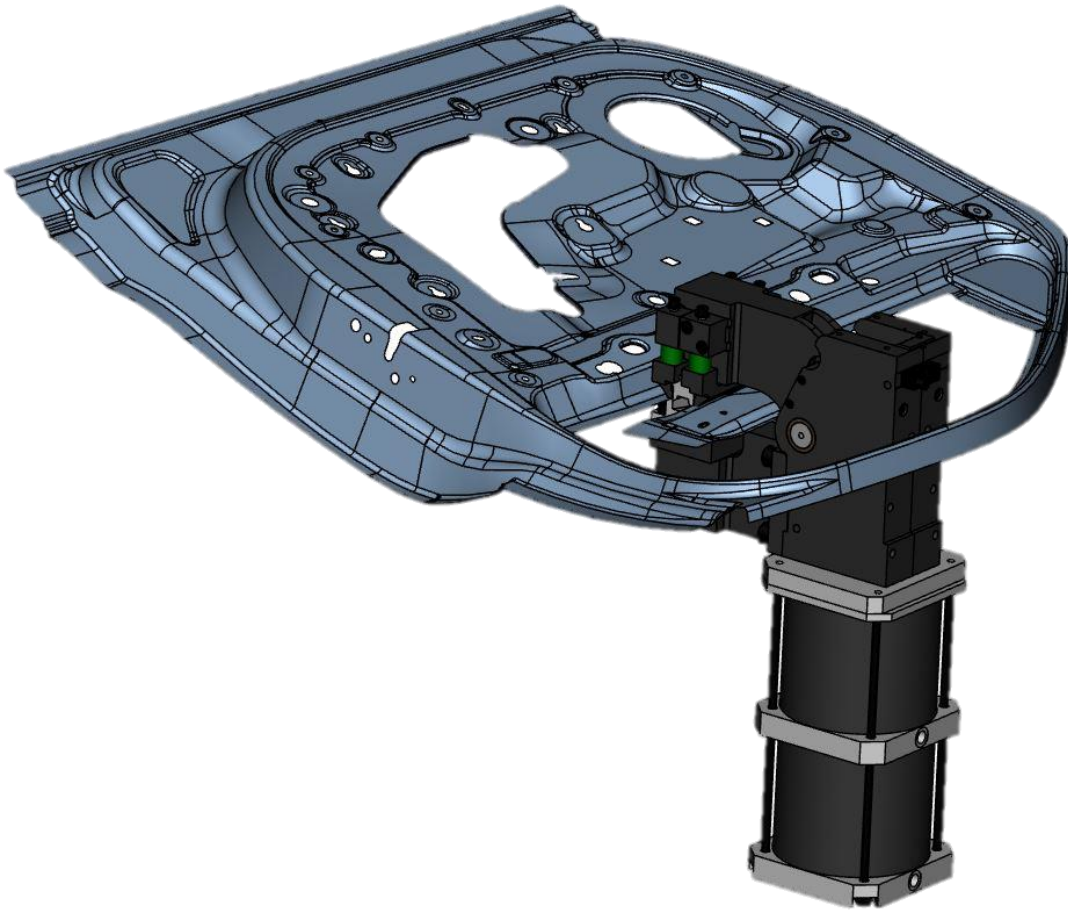

Kunde / Customer: Peugeot

- PFS 900-120 S T12/2 60°
- Ausladung 120mm, Öffnungswinkel 60°
- Schnittlänge 2x 60mm
- Stahlblech 0,65mm dick

- *PFS 900-120 S T12/2 60°*
- *Reach 120mm, opening angle 60°*
- *Cutting length 2x 60mm*
- *Steel sheet 0,65mm thick*

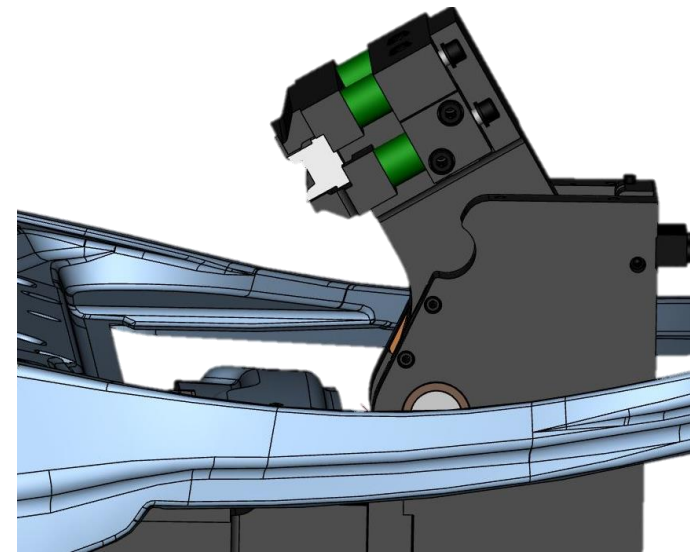

Stanzan mit CBMZ – Wasserfangleiste

Piercing with CBMZ – A-Pillar

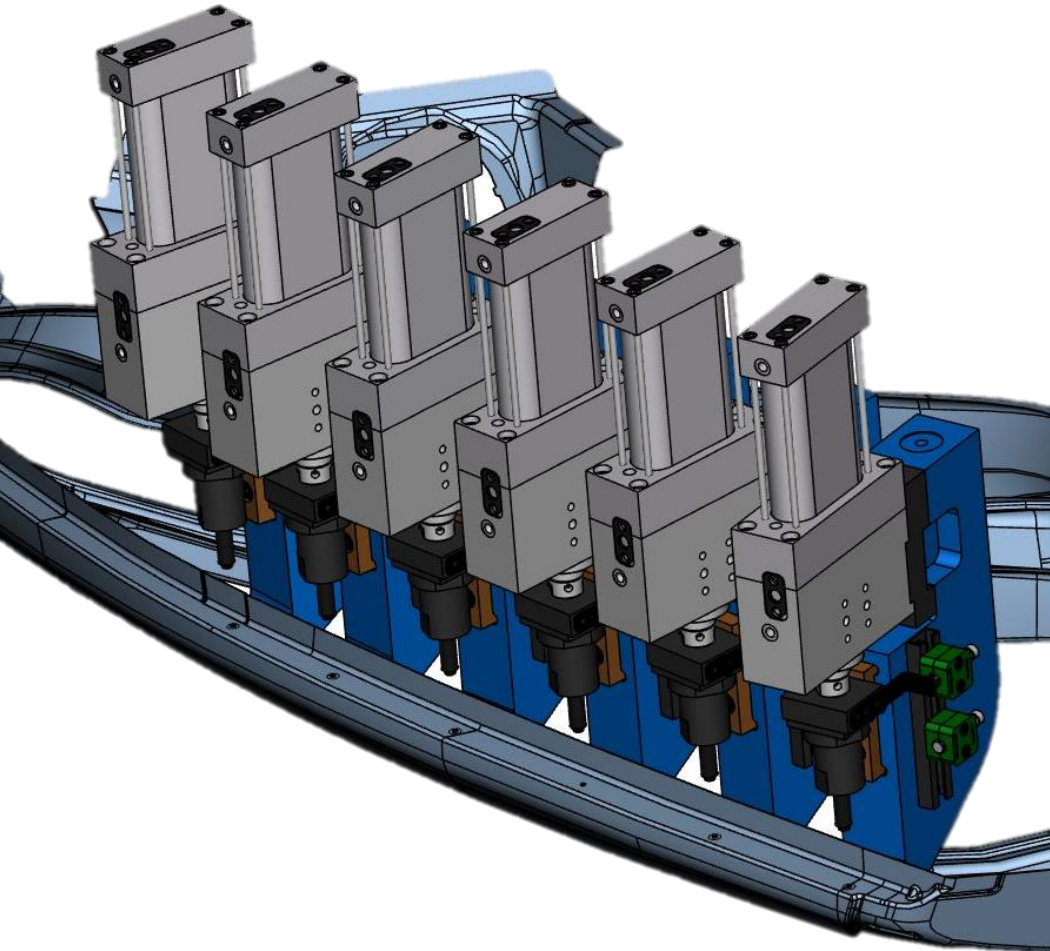

Kunde / Customer: JAC Motors (China)

- CBMZ 10-30 50 S für Ø4,5mm Löcher
 - MZ 63 (10kN) mit 50mm Hub
 - C-Bügel mit 30mm Ausladung
 - Butzenabfuhr per Vakuumabsaugung
 - Stahlblech 0,7mm dick
-
- *CBMZ 10-30 50 S for Ø4,5mm holes*
 - *MZ 63 (10kN) with 50mm stroke*
 - *C-Frame with 30mm reach*
 - *vacuum unit for slug disposal*
 - *Steel sheet 0,7mm thick*

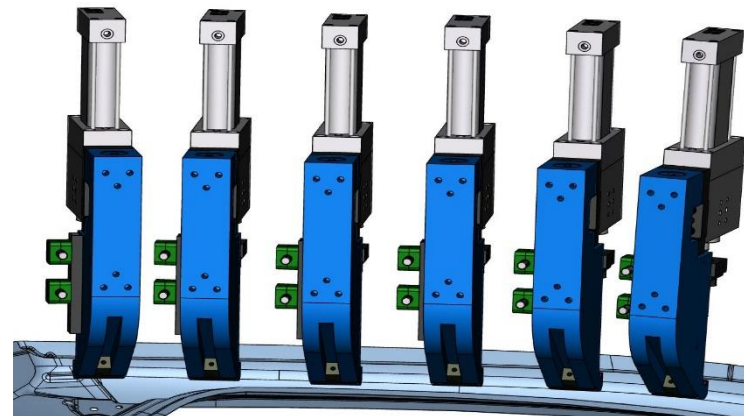

Stanzan mit PFS – Tür vorne

Piercing with PFS – Front door

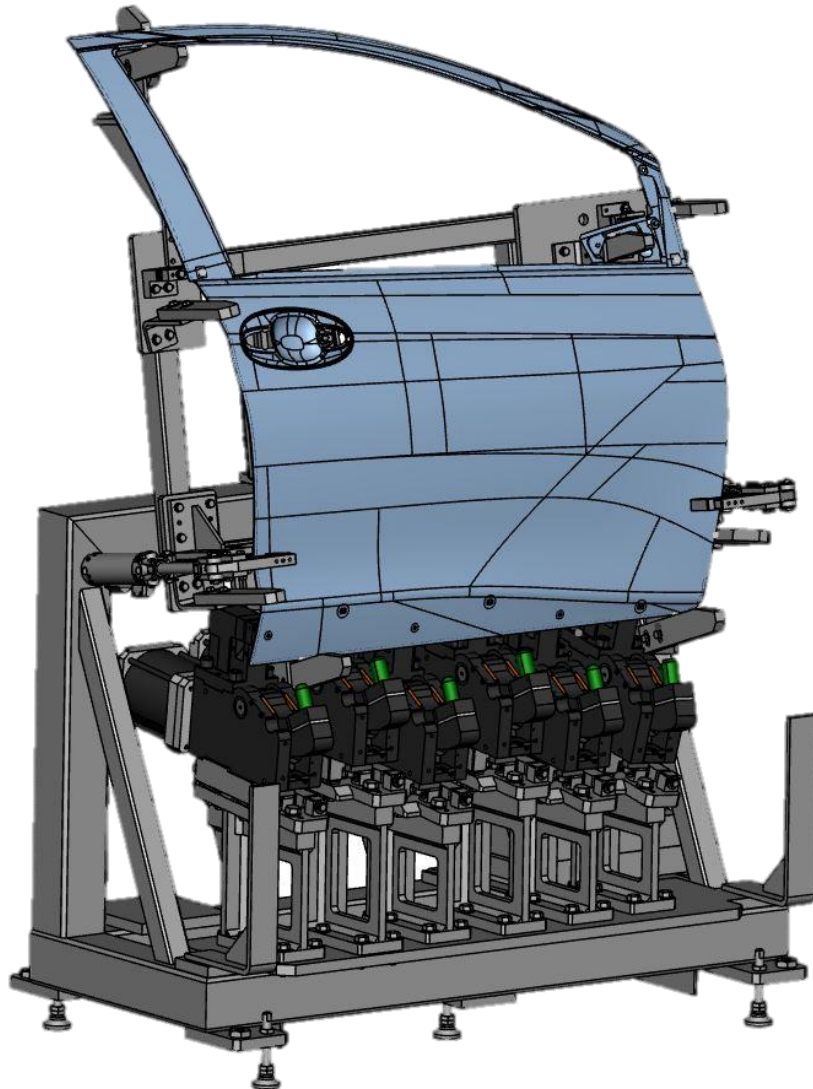

Kunde / Customer: Toyota France

- PFS 400-90 S T12/2 60° für Ø7mm Löcher
 - Ausladung 90mm, Öffnungswinkel 60°
 - Butzenabfuhr kiefenseitig durch Vakuumeinheit
 - Stahlblech 0,65mm dick
-
- *PFS 400-90 S T12/2 60° for Ø7mm holes*
 - *Reach 90mm, Opening angle 60°*
 - *Slug disposal through side of the jaw via vacuum unit*
 - *Steel sheet 0,65mm thick*

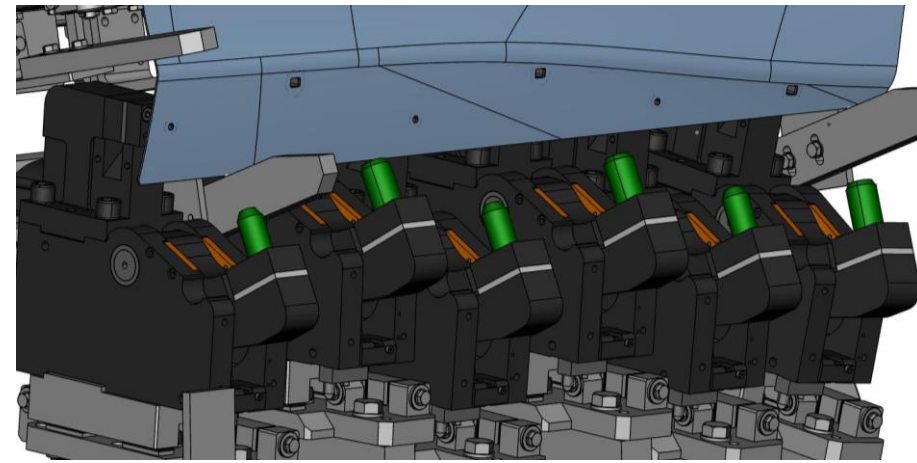

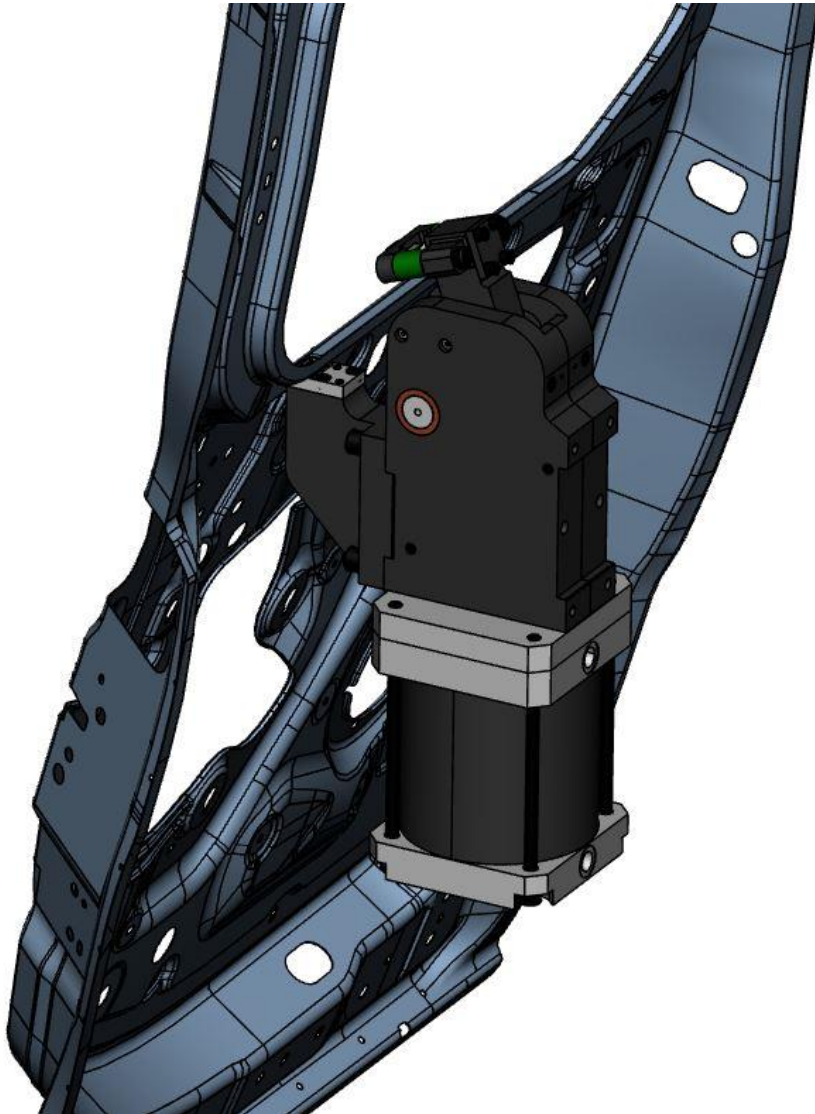

Kunde / Customer: PSA

- PFS 200-80 S T12/2 70° für 16,6 x 8,2mm Loch
- Ausladung 80mm, Öffnungswinkel 70°
- Stahlabstreifer nötig wegen Platzmangel
- Stahlblech 0,65mm dick

- *PFS 200-80 S T12/2 70° for 16,6 x 8,2mm hole*
- *Reach 80mm, Opening angle 70°*
- *Steel retainer used because of confined space*
- *Steel sheet 0,65mm thick*

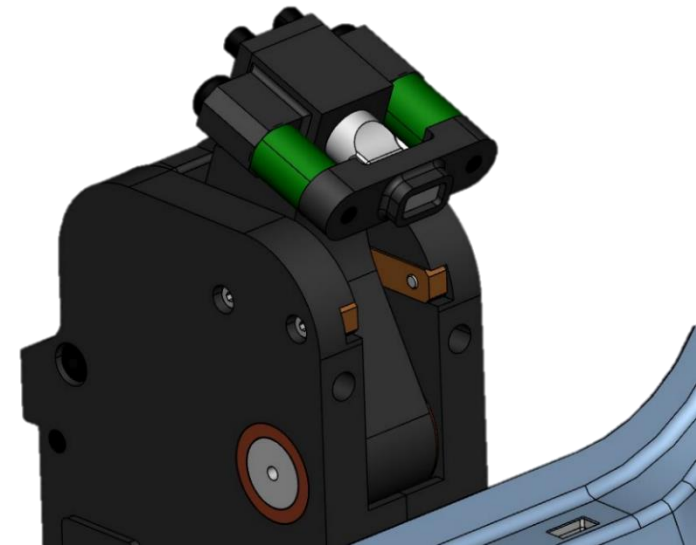

Stanzan mit CBPZ – Türrahmen

Piercing with CBPZ – Door frame

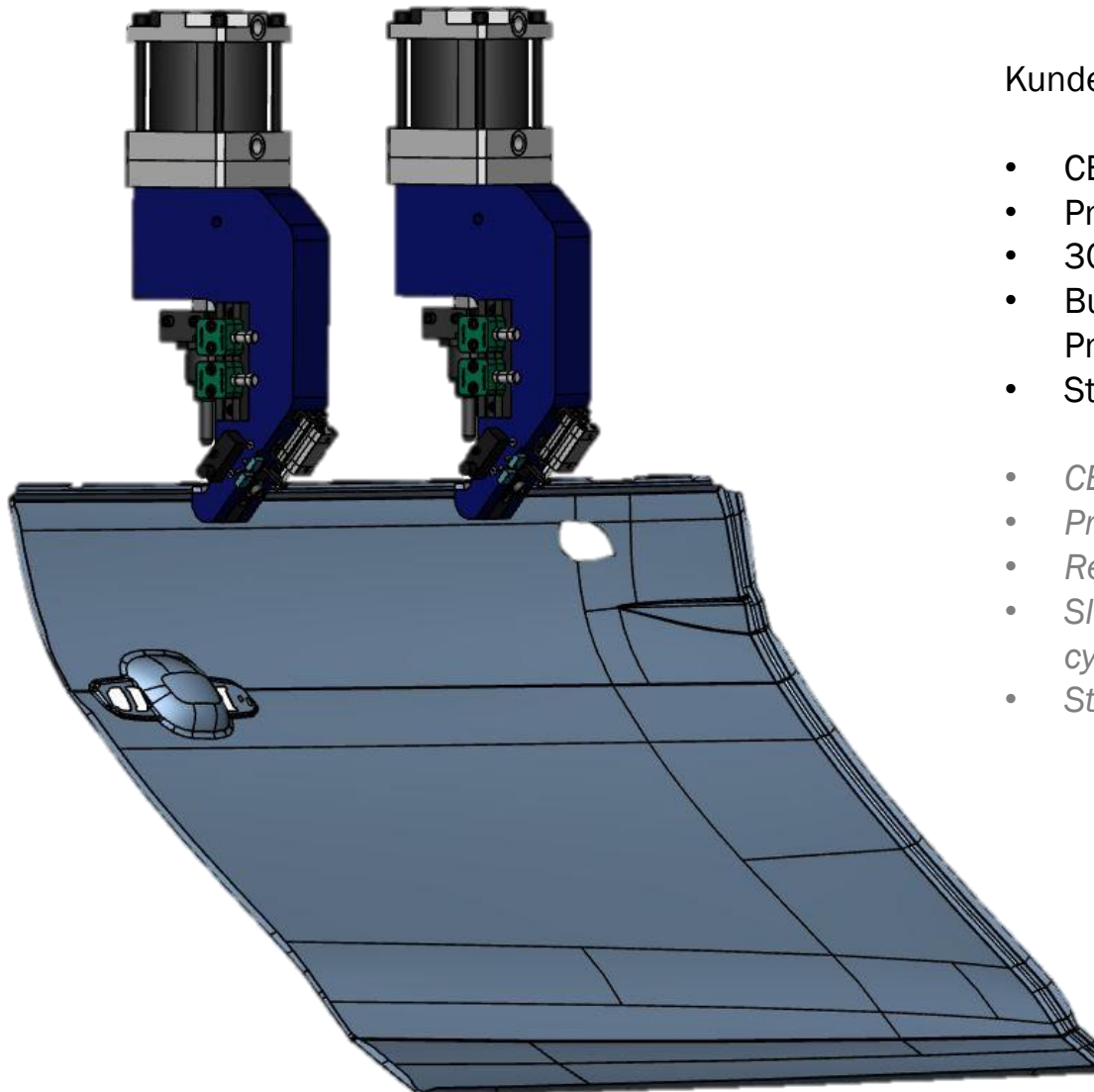

Kunde / Customer: AUDI

- CBPZ 4-30 40 S für Ø 3mm Löcher
 - Pneumatikzylinder mit 40mm Hub
 - 30mm Ausladung
 - Butzenklappe gesteuert durch Pneumatikzylinder
 - Stahlblech 0,65mm dick
-
- *CBPZ 4-30 40 S for Ø 3mm holes*
 - *Pneumatic cylinder with 40mm stroke*
 - *Reach 30mm*
 - *Slug disposal flap operated by pneumatic cylinder*
 - *Steel sheet 0,65mm thick*

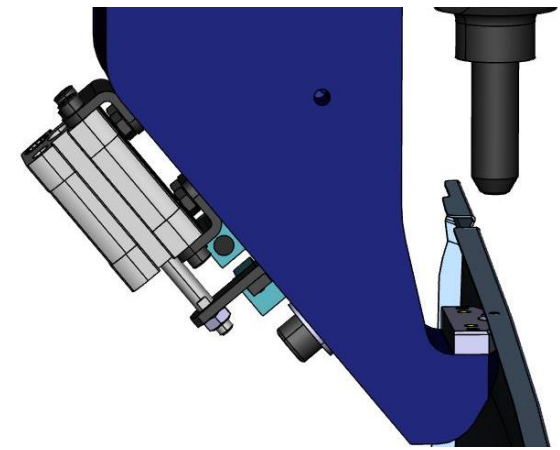

Stanzen mit PFS – Türrahmen hinten

Piercing with PFS – Door frame rear door

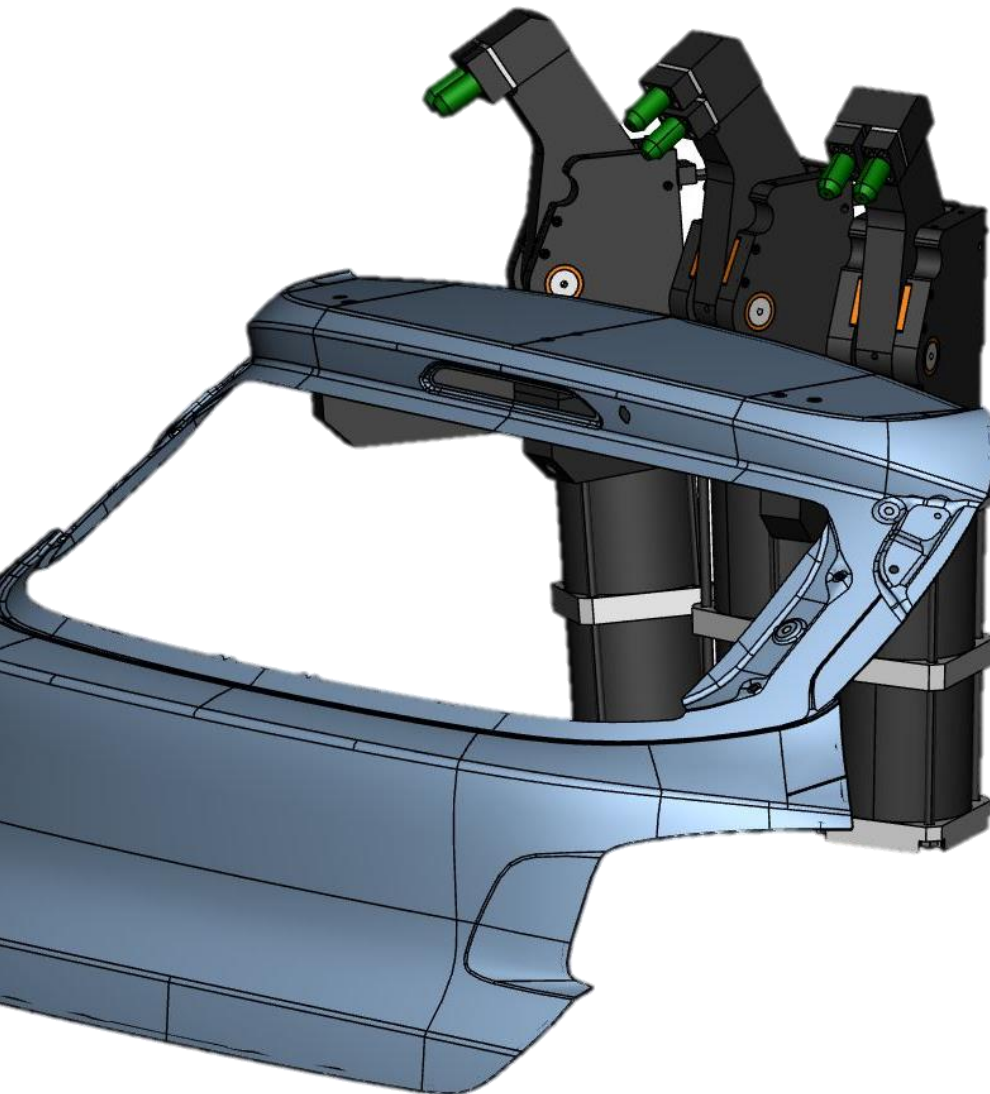

Kunde / Customer: GM

- PFS 900-180 S T12/3 60° für 2 Löcher
- Ausladung 180mm, Öffnungswinkel 60°
- Stahlblech 0,6mm dick
- *PFS 900-180 S T12/3 60° for 2 holes*
- *Reach 180mm, Opening angle 60°*
- *Steel sheet 0,6mm thick*

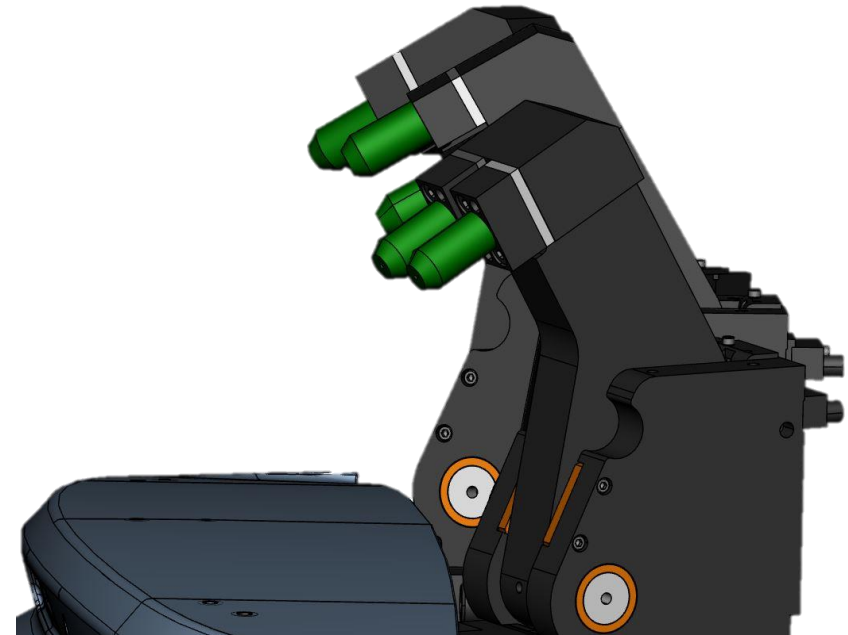

Abschneiden mit PFS – Türrahmen

Cutting with PFS – Door frame

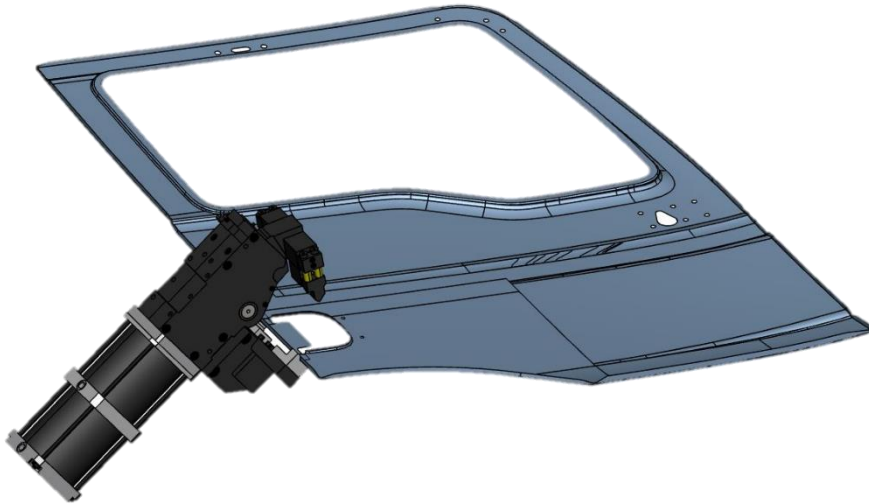

Kunde / Customer: MAN

- PFS 900-90 S T12/3 60° für 2 Schnitte
- Ausladung 90mm, Öffnungswinkel 60°
- Schnittlänge 2x ca. 26mm
- Stahlblech 1,0mm dick

- *PFS 900-90 S T12/3 60° for 2 cuts*
- *Reach 90mm, opening angle 60°*
- *Cutting length 2x approx. 26mm*
- *Steel sheet 1,0mm thick*

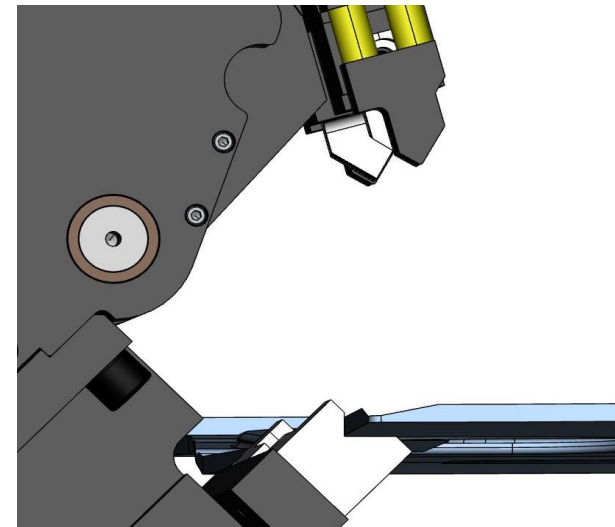
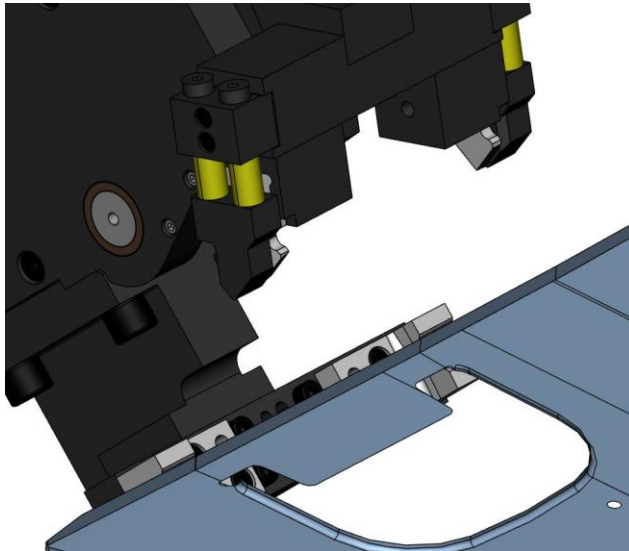

Stanzan mit PFS – Seitenteil

Piercing with PFS – Side panel

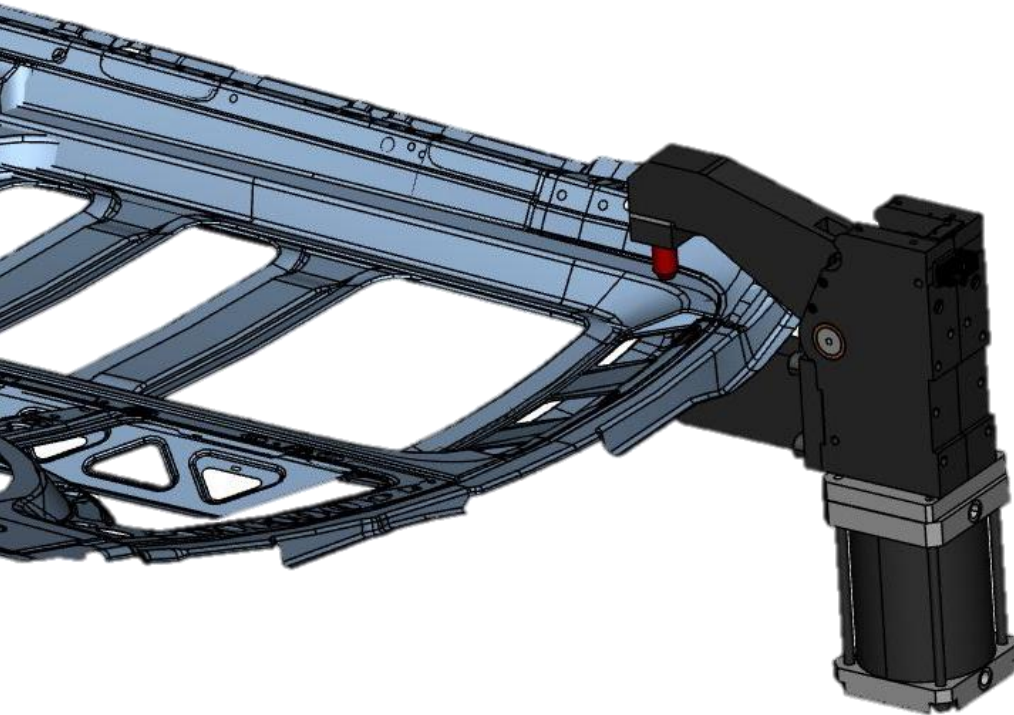

Kunde / Customer: VW

- PFS 400-190 S T12/3 75° Ø 6,5mm Loch
- Ausladung 190mm, Öffnungswinkel 75°
- Stahlblech 1,0mm dick

- *PFS 400-190 S T12/3 75° for Ø 6,5mm hole*
- *Reach 190mm, opening angle 75°*
- *Steel sheet 1,0mm thick*

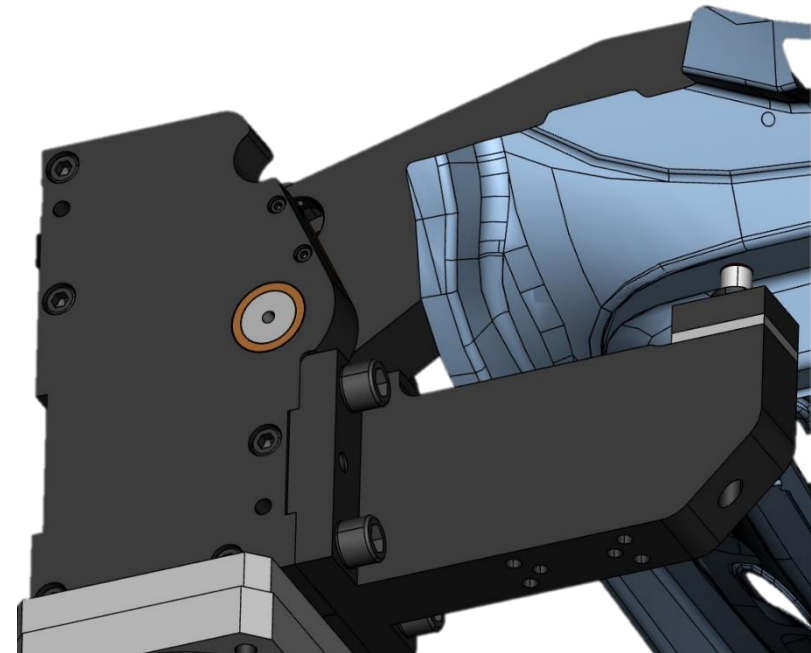

Stanzan mit CBMZ – Radhaus hinten

Piercing with CBMZ – Wheel house

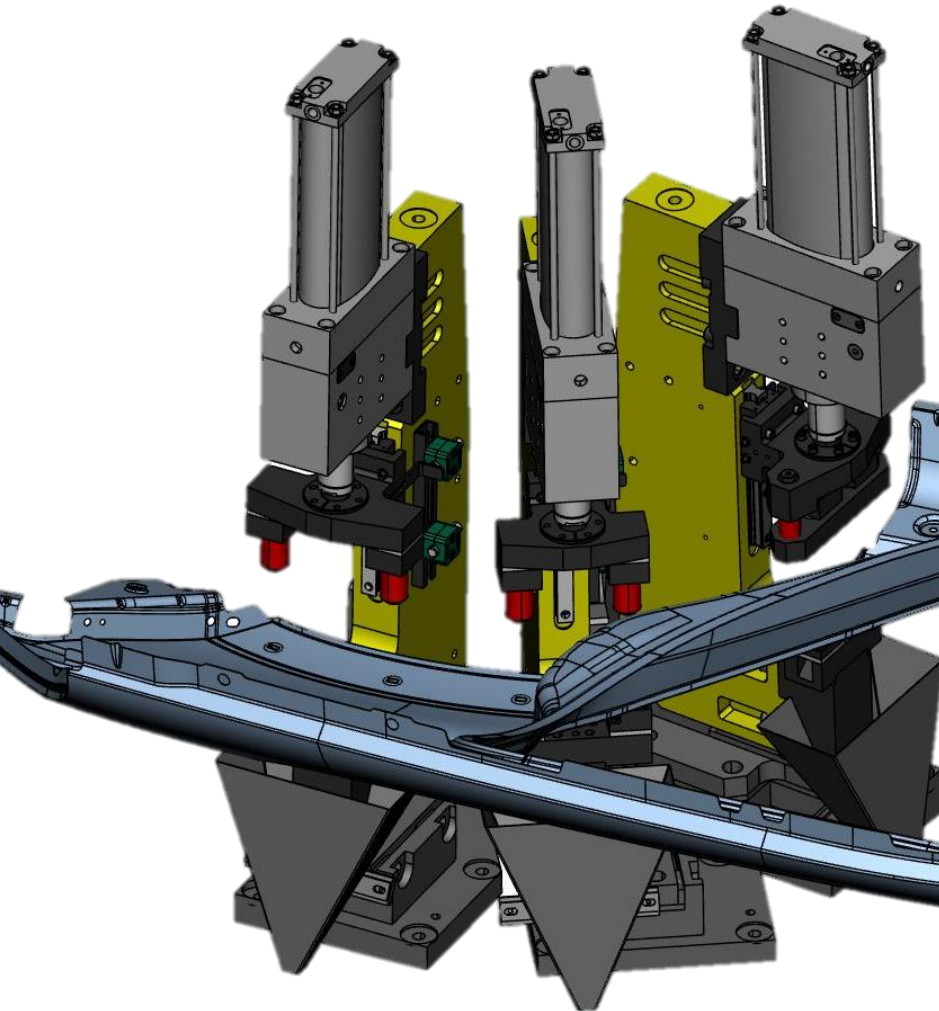

Kunde / Customer: TAM

- CBMZ 25-100 100 S für 2 Löcher
 - MZ 80 (25kN) mit 100mm Hub
 - C-Bügel mit 100mm Ausladung
 - Stahlblech 0,6mm dick
-
- *CBMZ 25-100 100 S for 2 holes*
 - *MZ 80 (25kN) with 100mm stroke*
 - *C-Frame with 100mm reach*
 - *Steel sheet 0,6mm thick*

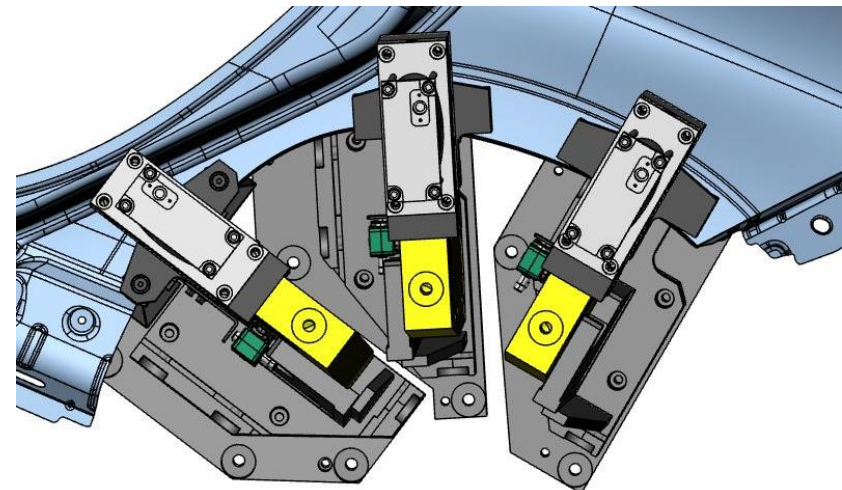

Stanzan mit PFS – Türrahmen

Piercing with PFS – Door frame

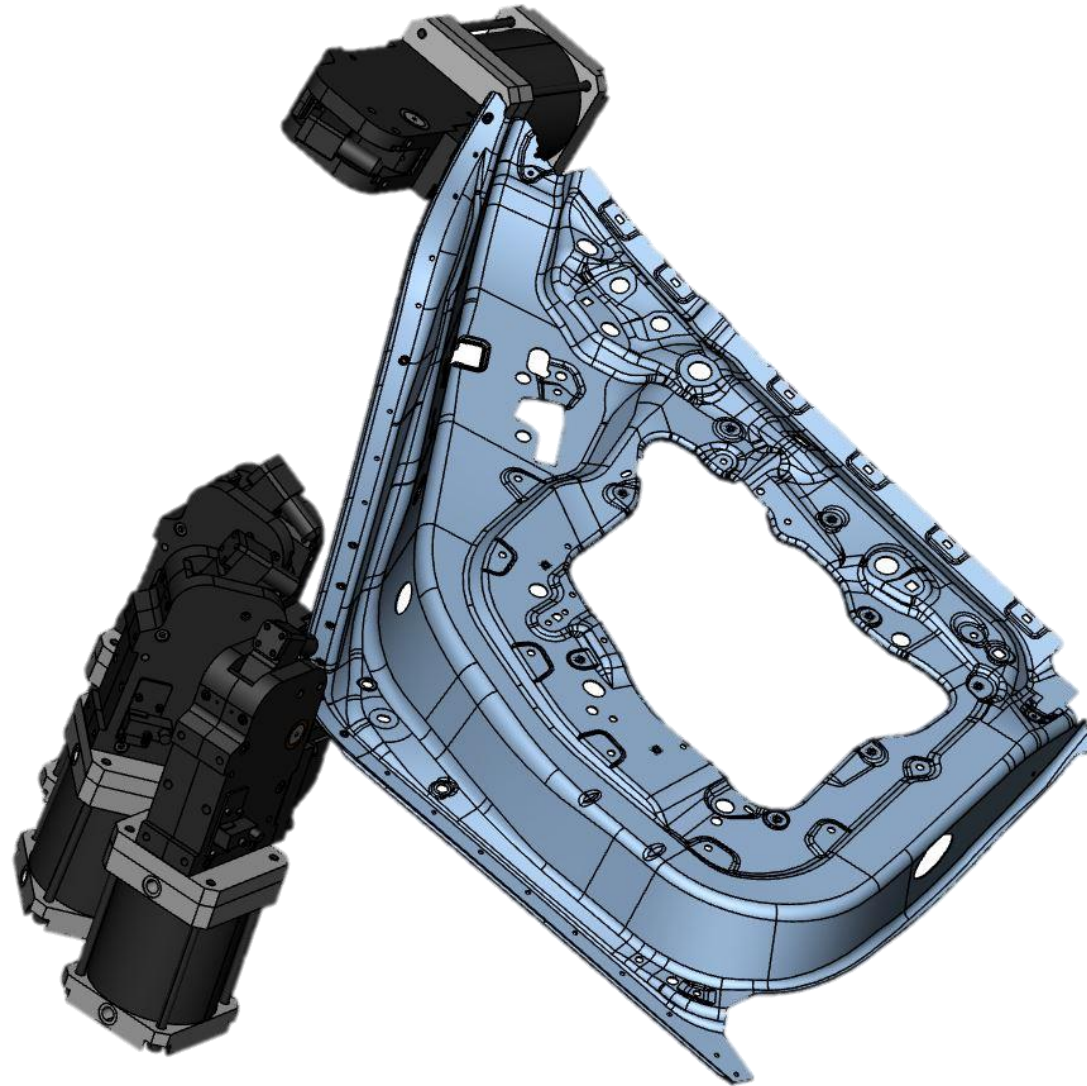

Kunde / Customer: BMW

- PFS 200-60 S T12/3 70° für Ø 5,1mm Loch
 - Ausladung 60mm, Öffnungswinkel 70°
 - Konturmatrixe angepasst an Bauteilkontur
 - Aluminiumblech 1,2mm dick
-
- *PFS 200-60 S T12/3 70° Ø 5,1mm hole*
 - *Reach 60mm, opening angle 70°*
 - *Die with 3D surface according to part contour*
 - *Aluminium sheet 1,2mm thick*

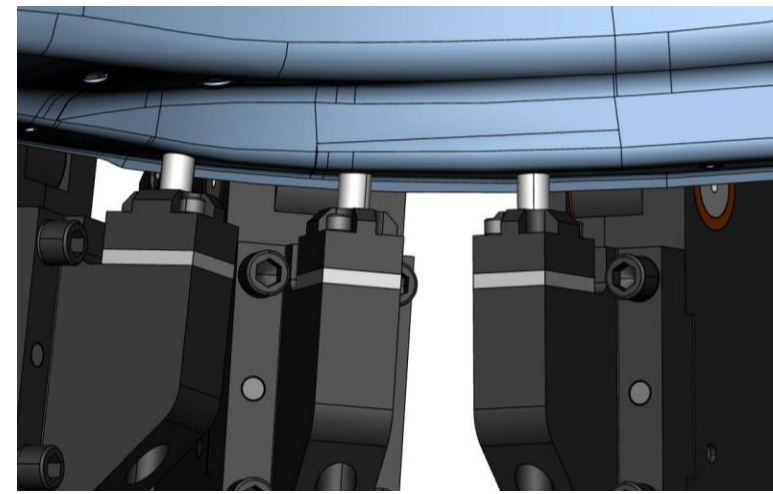

Stanzan mit CBMZ – Radhaus

Piercing with CBMZ – Wheel house

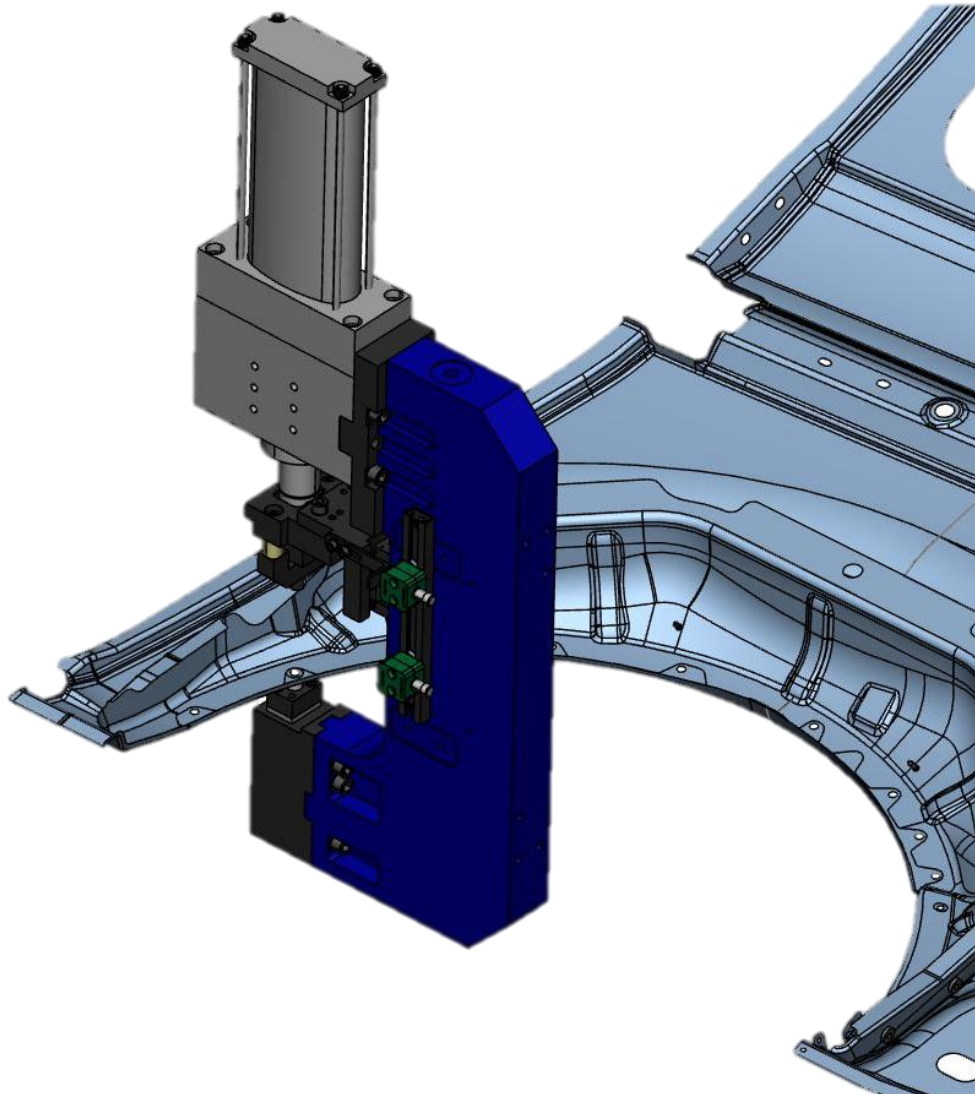

Kunde / Customer: Ford

- CBMZ 25-140 150 S für Ø8,7mm Löcher
 - MZ 80 (25kN) mit 150mm Hub
 - C-Bügel mit 140mm Ausladung
 - Stahlblech 0,8mm dick
-
- *CBMZ 25-140 150 S for Ø8,7mm holes*
 - *MZ 80 (25kN) with 150mm stroke*
 - *C-Frame with 140mm reach*
 - *Steel sheet 0,8mm thick*

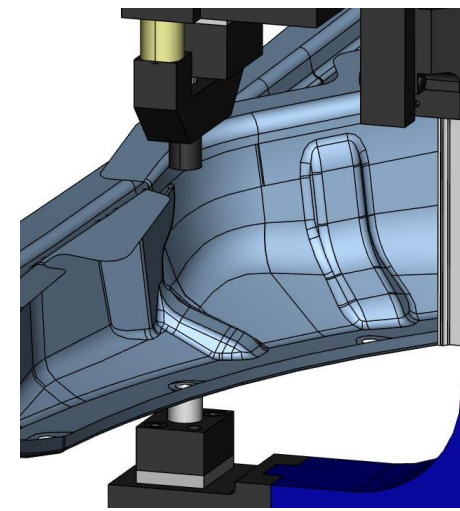

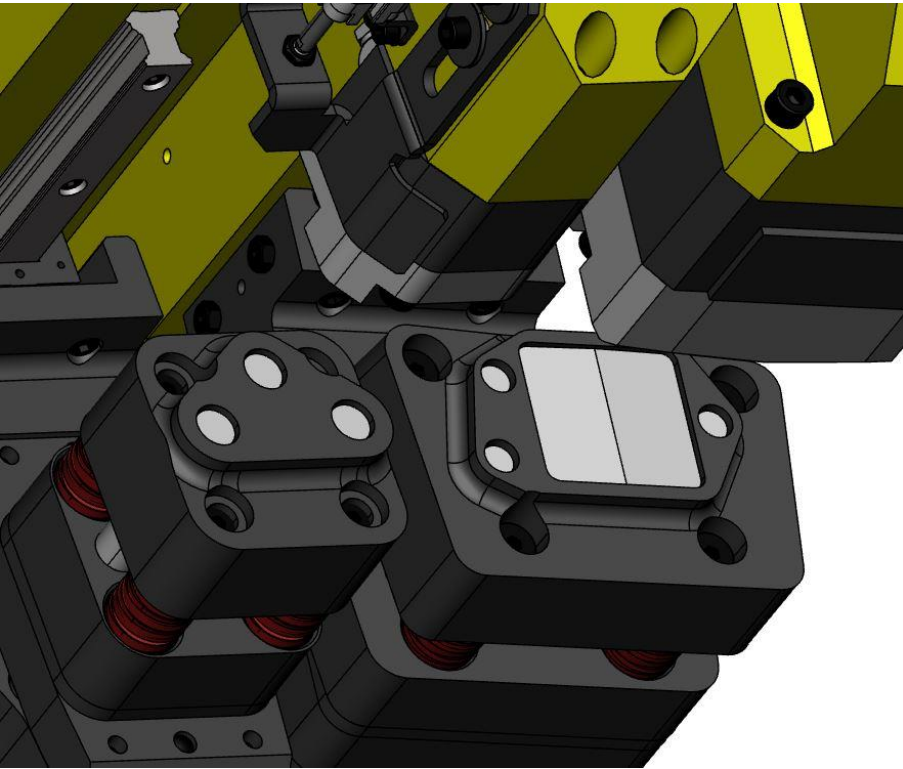

Kunde / *Customer:* VW

- CBHA 60-140 100 S für 3 bzw. 4 Löcher
- Kraftpaket U65 (65kN) mit 100mm Hub
- C-Bügel mit 140mm Ausladung
- Stahlblech 0,85mm dick

- *CBHA 65-140 100 S for 3 resp. 4 holes*
- *Powerpackage U65 (65kN) with 100mm stroke*
- *C-Frame with 140mm reach*
- *Steel sheet 0,85mm thick*

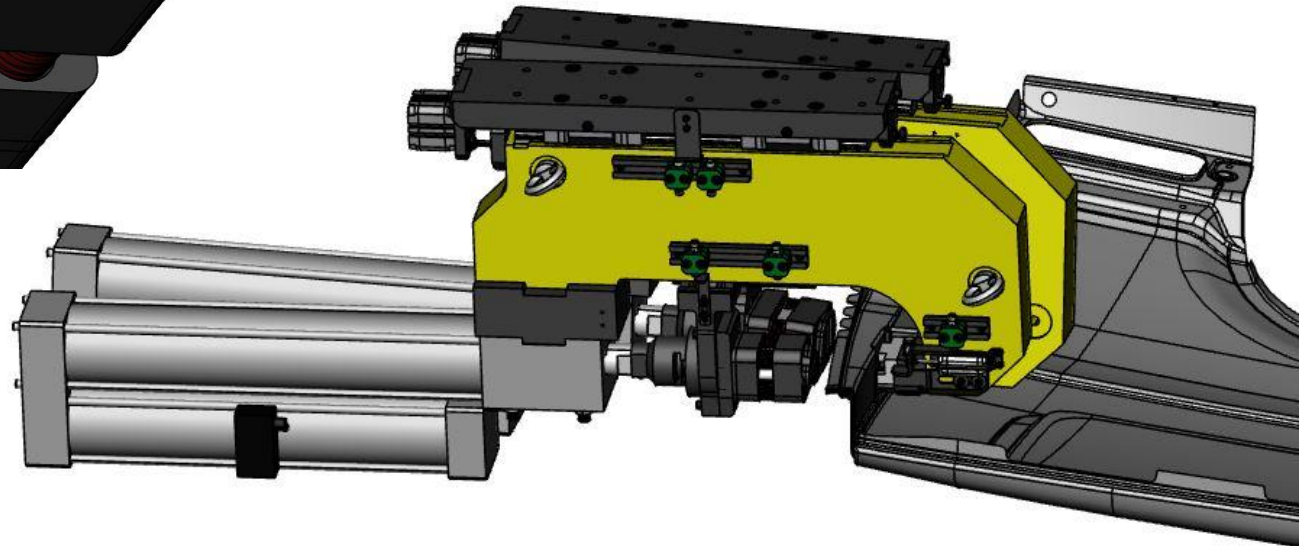

Stanzen mit CBHSD – Achsträger

Piercing with CBHSD – Axle carrier

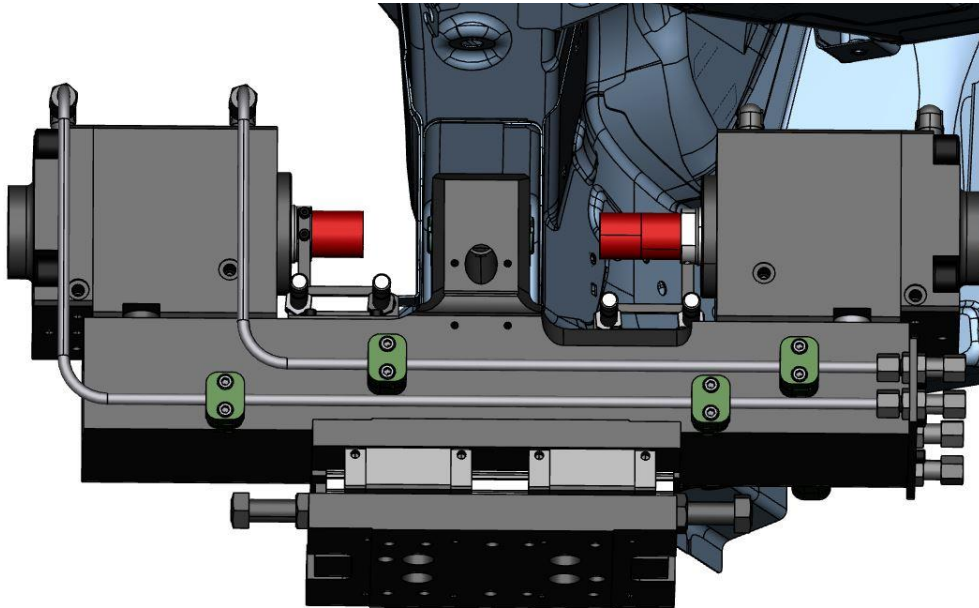

Kunde / Customer: Tata

- CBHSD 80-80-50 S für 2 Löcher
 - Hydraulikzylinder (80kN) mit 50mm Hub
 - Sonder-C-Bügel mit Horn
 - 2 Stahlbleche insgesamt 3,20mm dick
-
- *CBHSD 80-80-50 S for 2 holes*
 - *Hydraulic cylinder (80kN) with 50mm stroke*
 - *Special c-frame with horn*
 - *2 Steel sheets with a total thickness of 3.20mm*

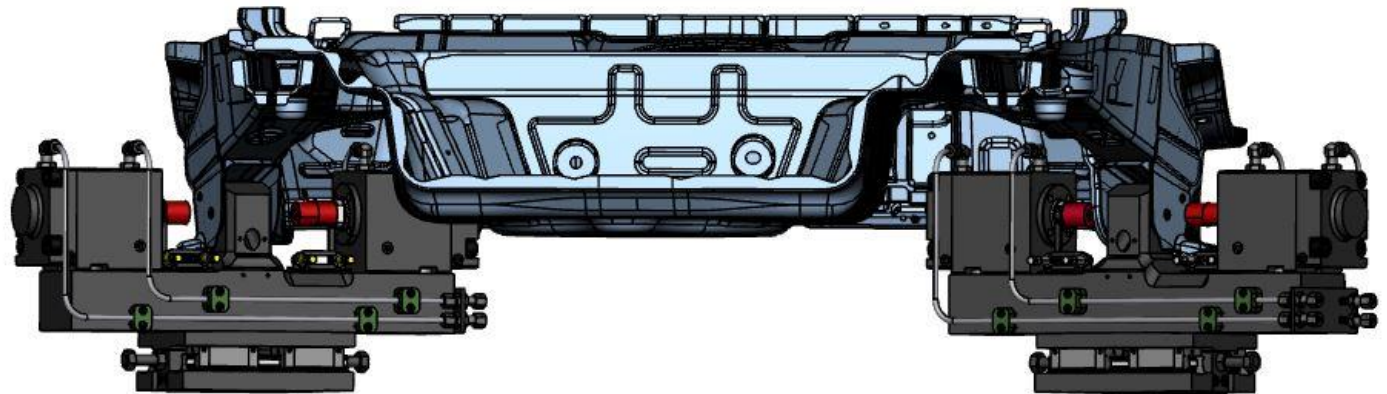

Schneiden mit PFS – Heckklappe

Cutting with PFS – Rear doors

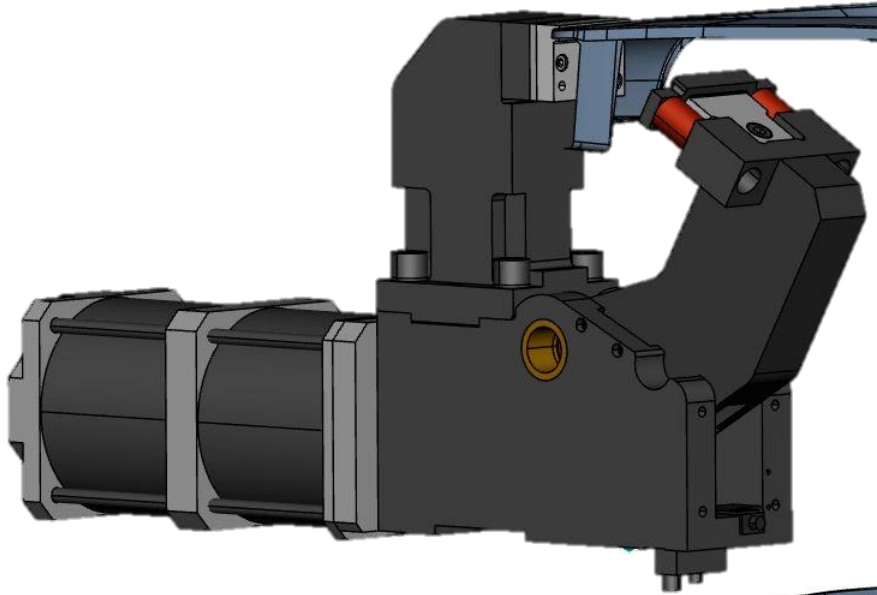

Kunde / Customer: Peugeot

- PFS 900-160 S T12/2 30°
- Ausladung 160mm, Öffnungswinkel 60°
- Schnittlänge ca. 61mm
- Stahlblech 0,65mm dick

- *PFS 900-160 S T12/2 30°*
- *Reach 160mm, opening angle 30°*
- *Cutting length approx. 61mm*
- *Steel sheet 0,65mm thick*

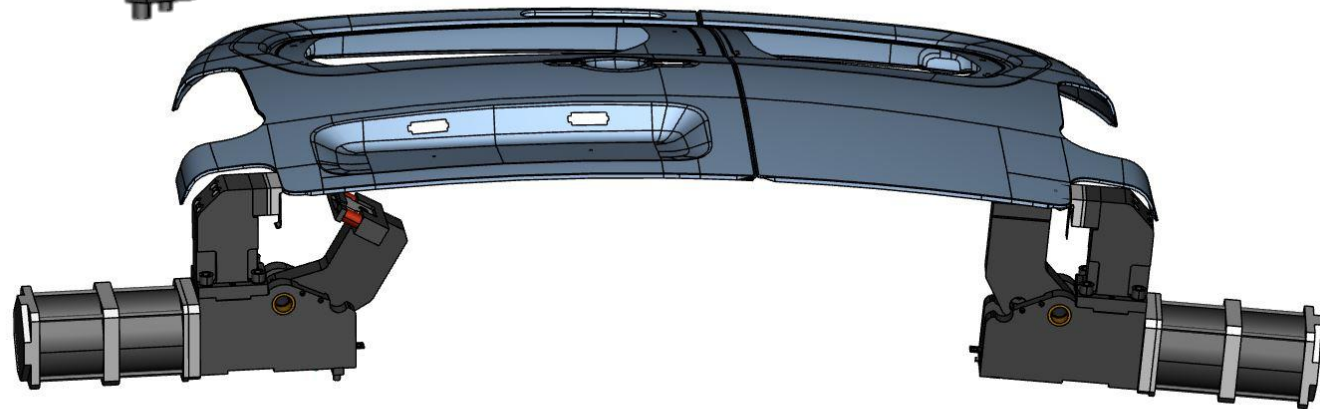

Stanzan mit CBMZ – Dach - Robotergerführt *Piercing with CBMZ – Roof – Robot-controlled*

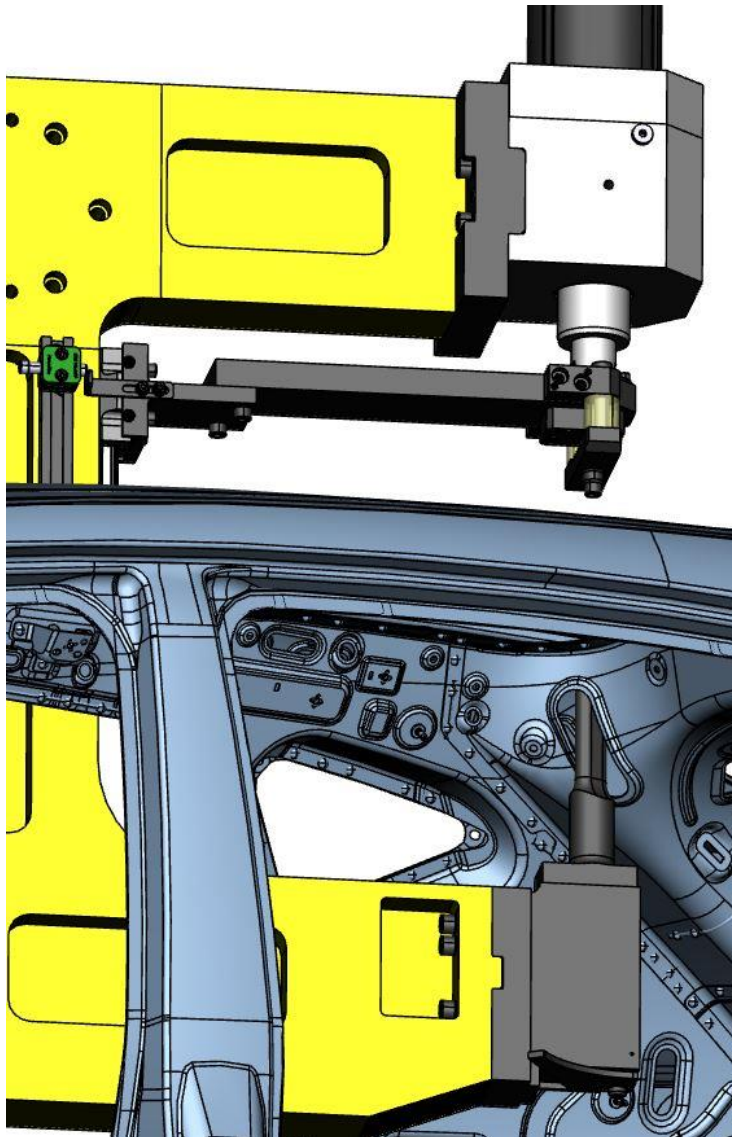

Kunde / *Customer:* SAIC

- CBMZ 45-450 150 S für Ø8mm Löcher
 - MZ 100 (45kN) mit 150mm Hub
 - C-Bügel mit 450mm Ausladung
 - Stahlblech 3,10mm dick
-
- *CBMZ 45-450 150 S for Ø8mm holes*
 - *MZ 100 (45kN) with 150mm stroke*
 - *C-Frame with 450mm reach*
 - *Steel sheet 3.10mm thick*

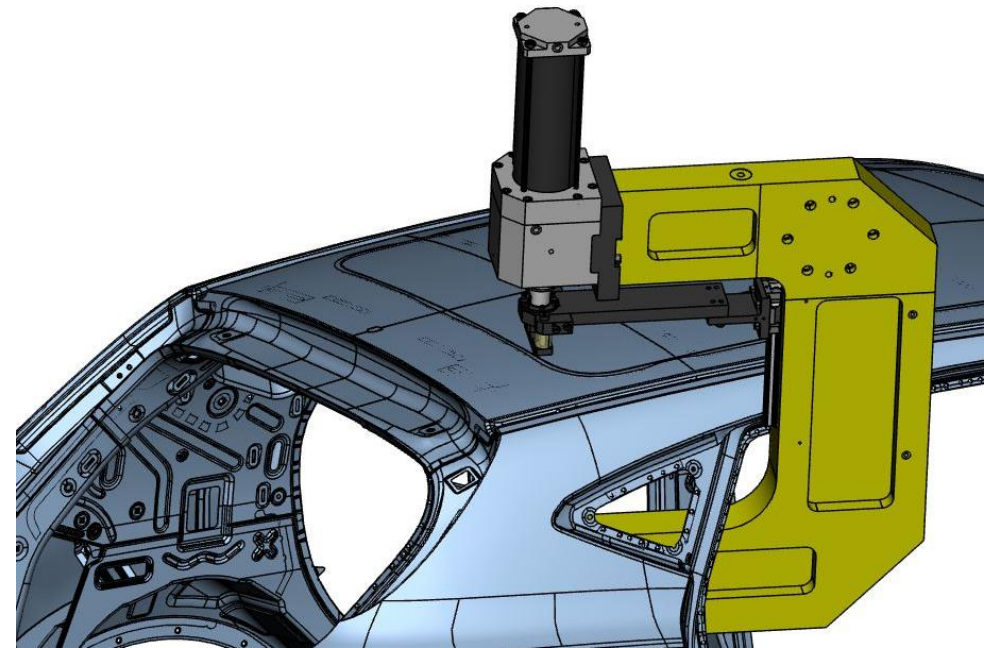

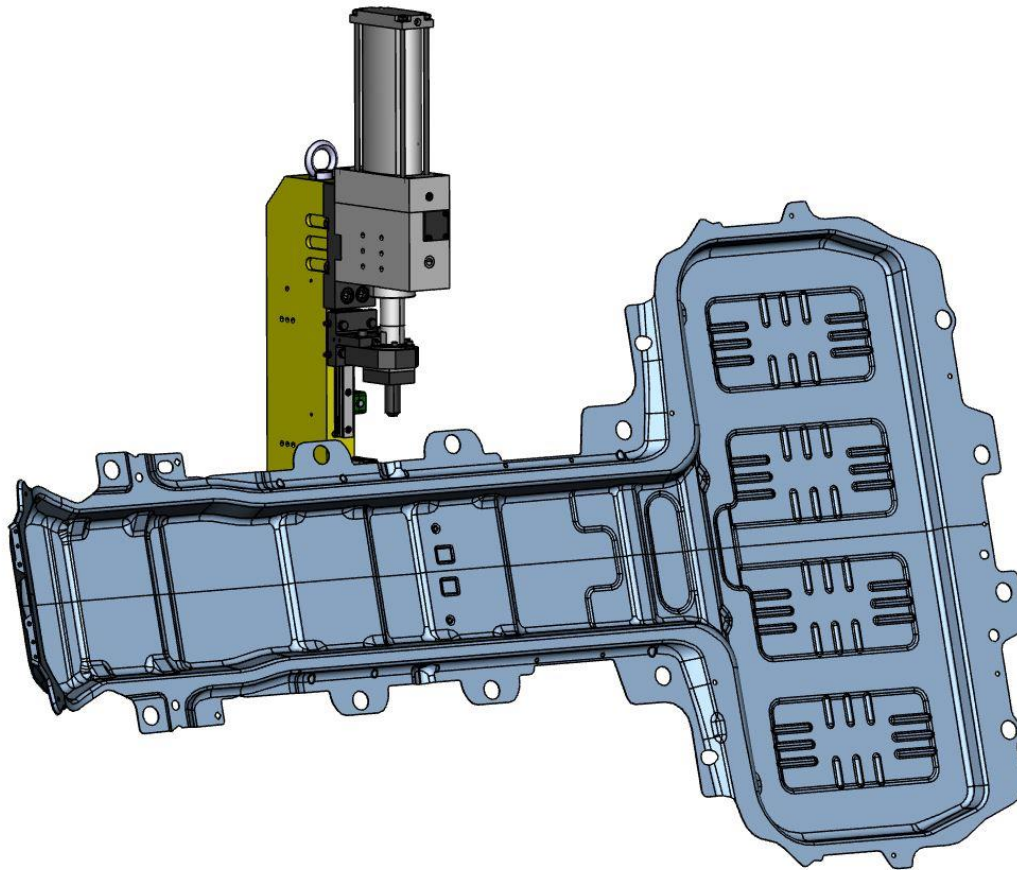

Kunde / Customer: BMW

- CBMZ 25-140 100 S für Ø9mm Löcher
- MZ 80 (25kN) mit 100mm Hub
- C-Bügel mit 140mm Ausladung
- Stahlblech 1,20mm dick

- *CBMZ 25-140 100 S for Ø9mm holes*
- *MZ 80 (25kN) with 100mm stroke*
- *C-Frame with 140mm reach*
- *Steel sheet 1.20mm thick*

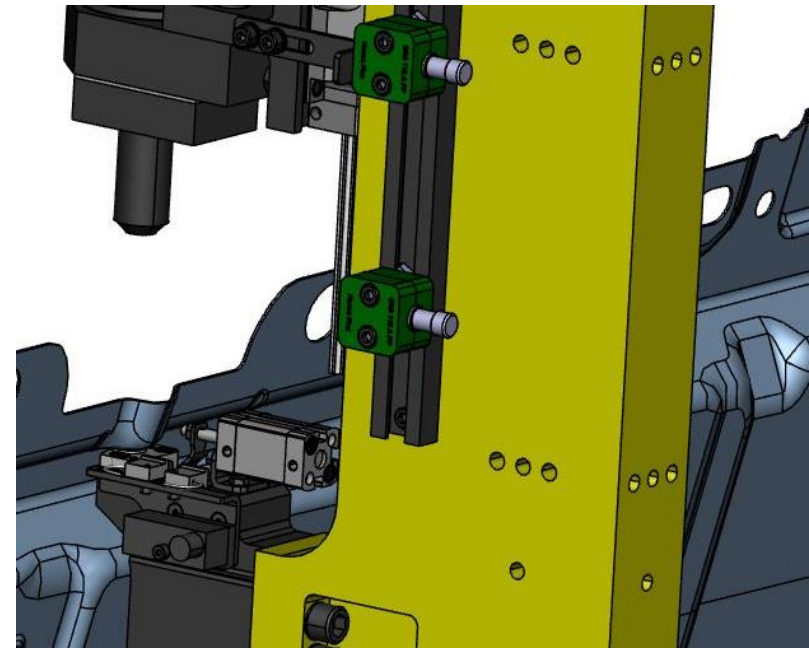

Stanzen mit CBEZ – Reserveradmulde

Piercing with CBEZ – spare wheel well

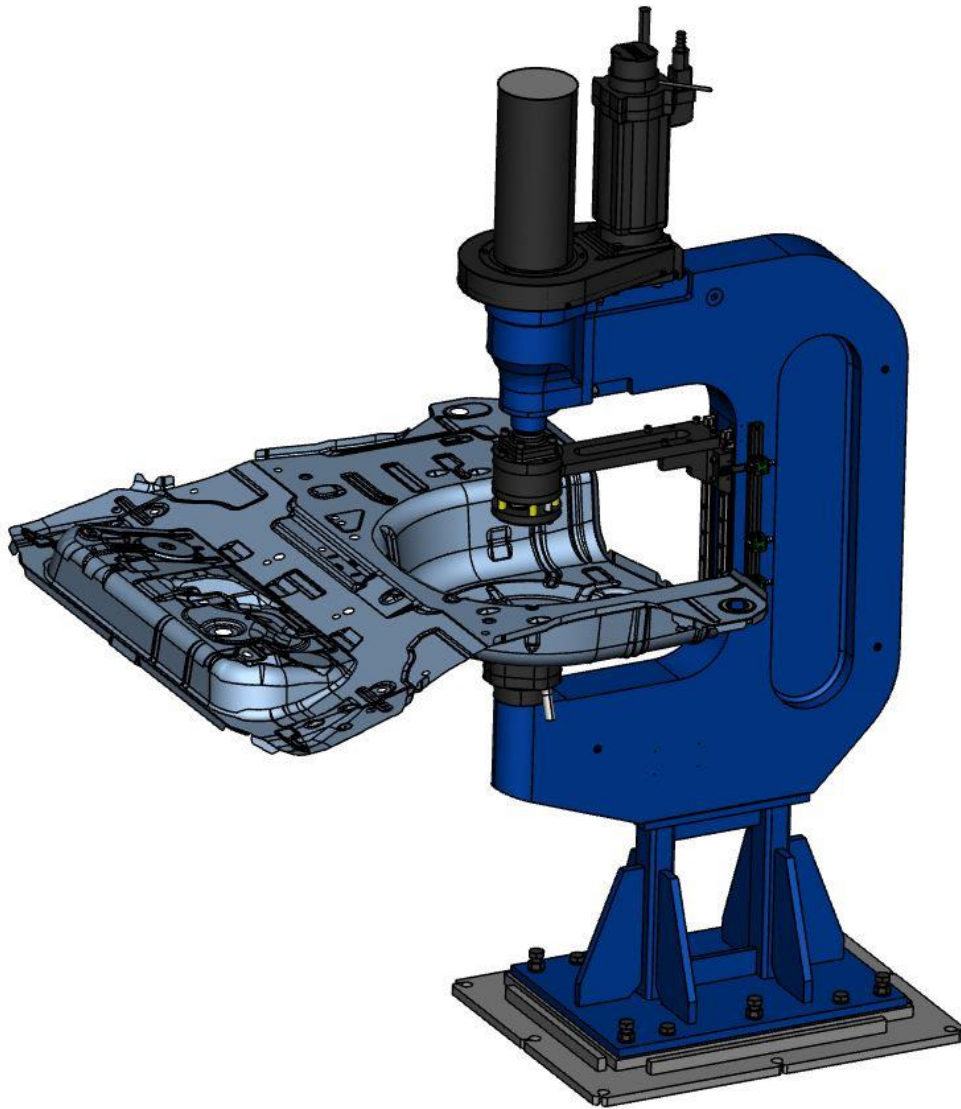

Kunde / Customer: FORD

- CBEZ 150-450 280 S für 1x Ø54mm und 1x Ø13mm Löcher
- Elektroantrieb (150kN) mit 280mm Hub
- C-Bügel mit 450mm Ausladung
- Stahlblech 0,70mm dick

- *CBEZ 150-450 280 S for 1x Ø54mm and 1x Ø13mm holes*
- *Electric drive (150kN) with 280mm stroke*
- *C-Frame with 450mm reach*
- *Steel sheet 0.70mm thick*

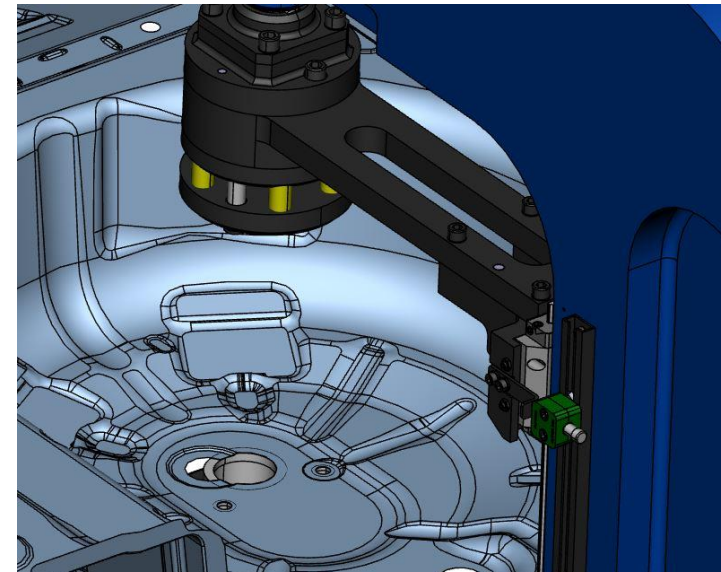

Stanz- und Schneiden mit PFS – Kotflügel

Piercing and cutting with PFS – Fender

Kunde / Customer: VW

- PFS 400-60 S T12/3 45° für 1x 13,5x11,5mm und 1x Ø11,5mm und Schnittlänge ca. 50mm
- Ausladung 60mm, Öffnungswinkel 45°
- Stahlblech 0,60mm dick
- *PFS 400-60 S T12/3 45° für 1x 13.5x11.5mm and 1x Ø11.5mm and cutting length approx. 50mm*
- *Reach 60mm, opening angle 45°*
- *Steel sheet 0.60mm thick*

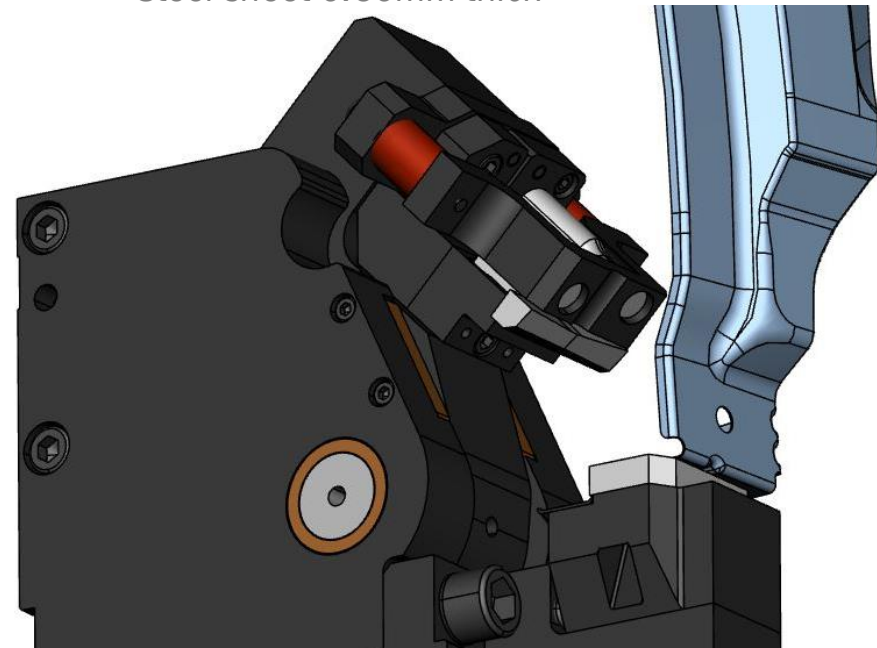
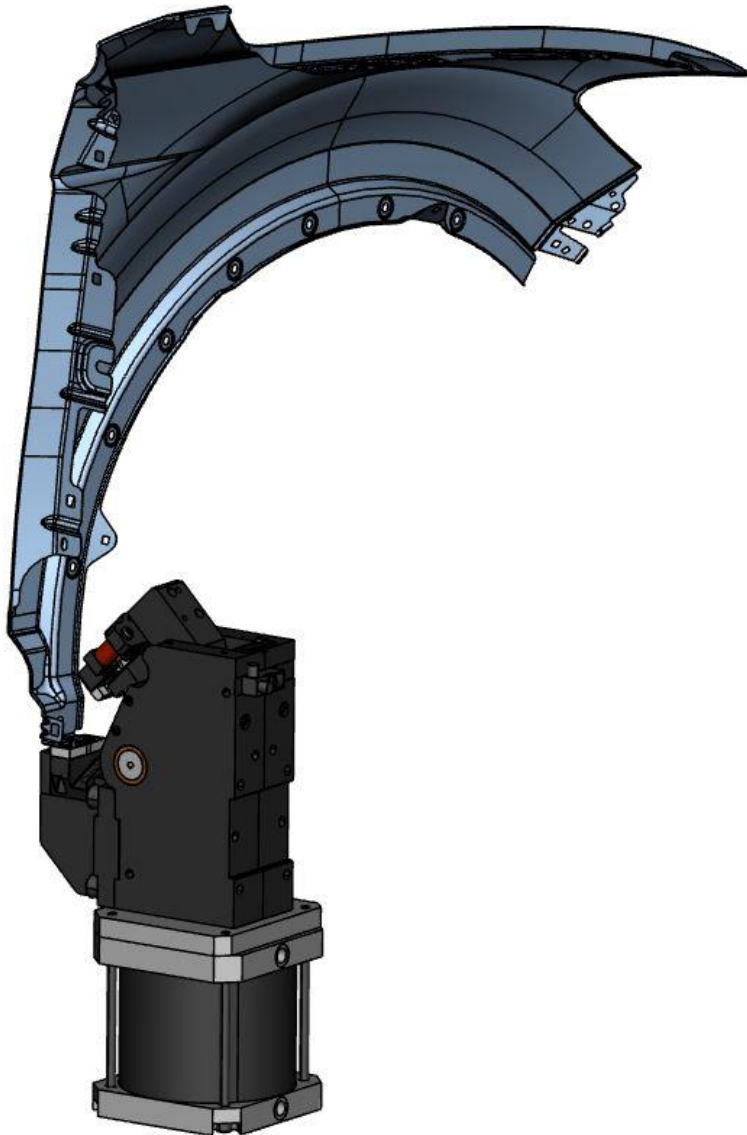

Schneiden mit PFS – Motorhaube

Cutting with PFS – Hood

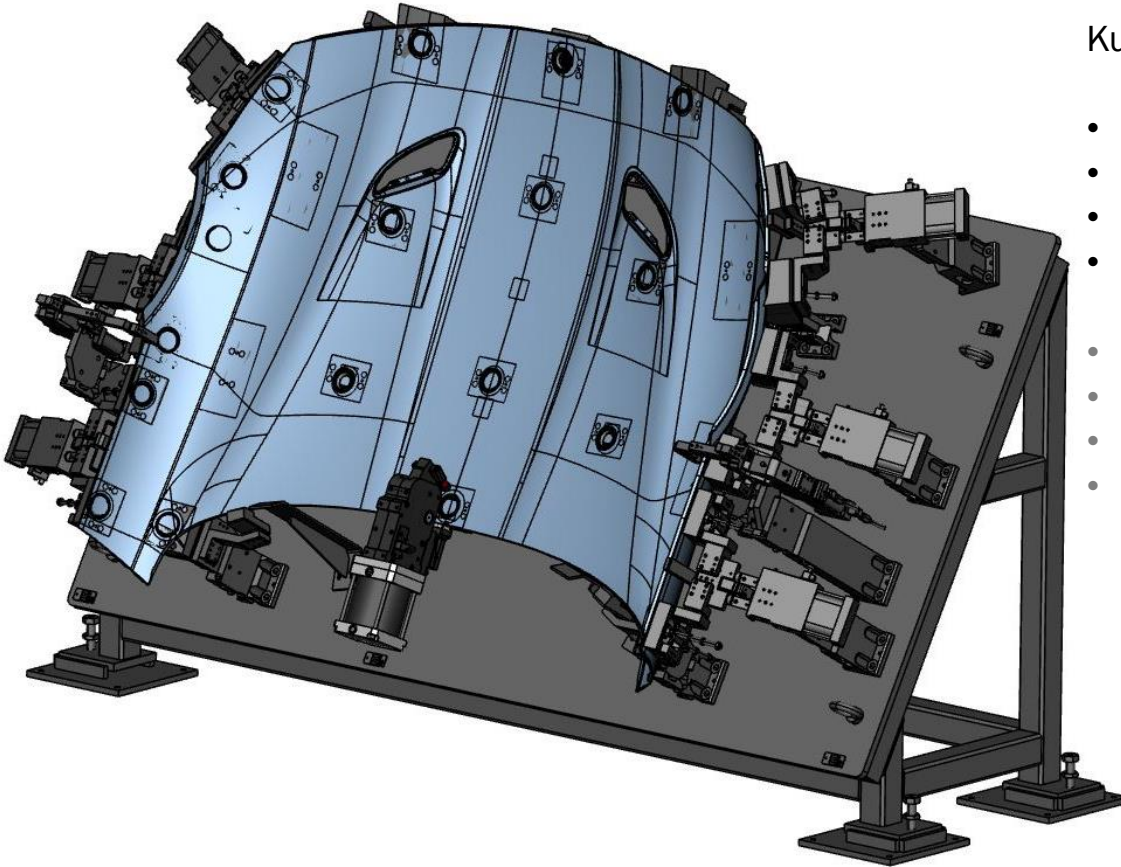

Kunde / Customer: Peugeot

- PFS 200-70 S T12/3 60°
 - Ausladung 70mm, Öffnungswinkel 60°
 - Schnittlänge ca. 2x 10mm
 - Aluminiumblech 1.0mm dick
-
- *PFS 200-70 S T12/3 60°*
 - *Reach 70mm, opening angle 60°*
 - *Cutting length approx. 2x 10mm*
 - *Aluminium sheet 1.0mm thick*

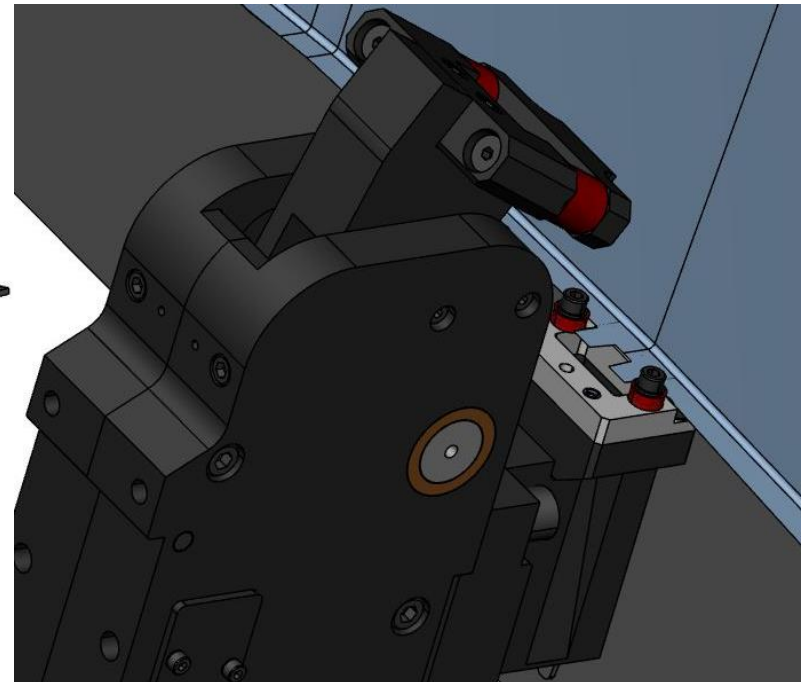

TÜNKERS Maschinenbau GmbH

Andre Michels
Product Manager Forming Technology

Am Rosenkothen 4-12
40880 Ratingen

Fon +49 (0) 2102-45 17-508
Fax +49 (0) 2102-45 17-9999

E-Mail andre.michels@tuenkers.de
Internet www.tuenkers.de

kontakt v ČR:

KOPTA, s.r.o.
Vážní 891, 500 03 Hradec Králové
Tel.: +420 495 531 210
E-Mail: kopta@kopta.cz

TÜNKERS Maschinenbau GmbH

Maximilian Kalesse
Manager Forming Technology

Am Rosenkothen 4-12
40880 Ratingen

Fon +49 (0) 2102-45 17-321
Fax +49 (0) 2102-45 17-9999

E-Mail maximilian.kalesse@tuenkers.de
Internet www.tuenkers.de